

 LITTLE
 WOMEN

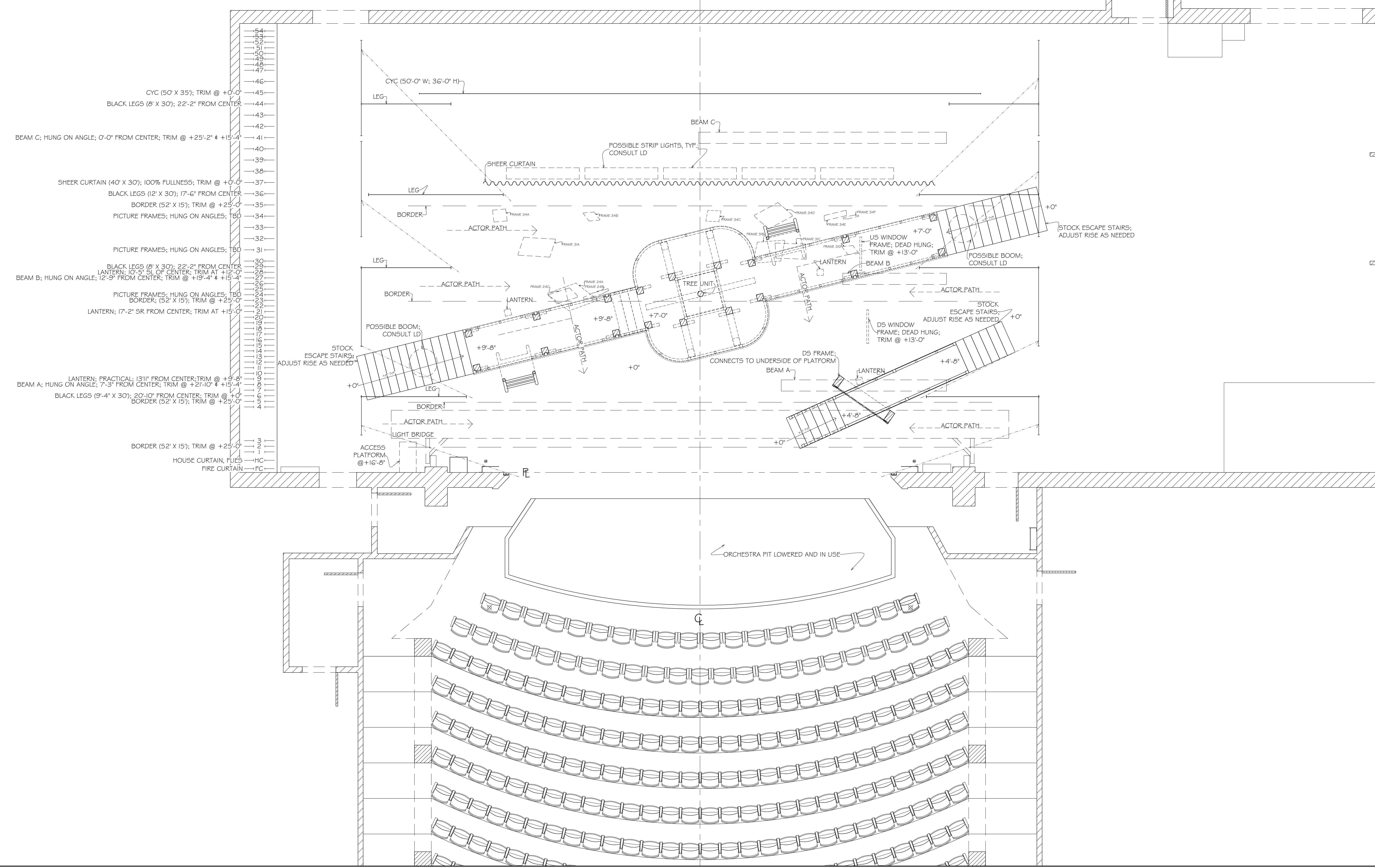

ALL MATERIALS, CONSTRUCTION AND FINISHES MUST COMPLY WITH THE MOST STRINGENT APPLICABLE FEDERAL AND LOCAL SAFETY CODES.
 THIS DRAWING AND ALL THE IDEAS, ARRANGEMENTS, DESIGNS AND PLANS CONTAINED HEREIN OR REPRESENTED THEREBY ARE OWNED AND REMAIN THE PROPERTY OF THE DESIGNER, AND HAVE BEEN CREATED AND DEVELOPED FOR USE ON, AND IN CONNECTION WITH, THE PROJECT SPECIFIED. NEITHER THIS DRAWING, NOR ANY OF SUCH IDEAS, ARRANGEMENTS, DESIGNS OR PLANS SHALL BE APPROPRIATED BY OR DISCLOSED TO ANY PERSON, FIRM OR CORPORATION FOR ANY USE WHATSOEVER, EXCEPT BY SPECIFIC AND WRITTEN PERMISSION OF THE DESIGNER.
 WRITTEN DIMENSIONS ON DRAWINGS SHALL HAVE AUTHORITY OVER SCALED, CONTRACTORS AND MANUFACTURERS SHALL VERIFY AND BE RESPONSIBLE FOR ALL DIMENSIONS AND CONDITIONS ON THE JOB, AND SHALL INFORM THE DESIGNER OF ALL VARIATIONS FROM DRAWINGS PRIOR TO PERFORMING THE WORK. THE DESIGNER SHALL FIRST SEE AND APPROVE CONTRACTORS FULL-SIZE DETAILS BEFORE ANY FABRICATION BEGINS.
 THESE DRAWINGS REPRESENT VISUAL CONCEPTS AND CONSTRUCTION SUGGESTIONS ONLY. THE DESIGNER AND HIS/HER EMPLOYEES AND ASSISTANTS ARE NOT QUALIFIED TO DETERMINE THE STRUCTURAL APPROPRIATENESS OF THESE DECISIONS, AND WILL NOT ASSUME RESPONSIBILITY FOR IMPROPER ENGINEERING, CONSTRUCTION AND/OR HANDLING OF THE SCENERY REPRESENTED HEREIN.

SCALE:	1/4" = 1'-0"
DRWG:	RACHEL ROSE BURKE
DATE:	03/04/2021
REVISION(S):	

DRAWING TITLE
GROUNDPLAN

SHEET NO.
1

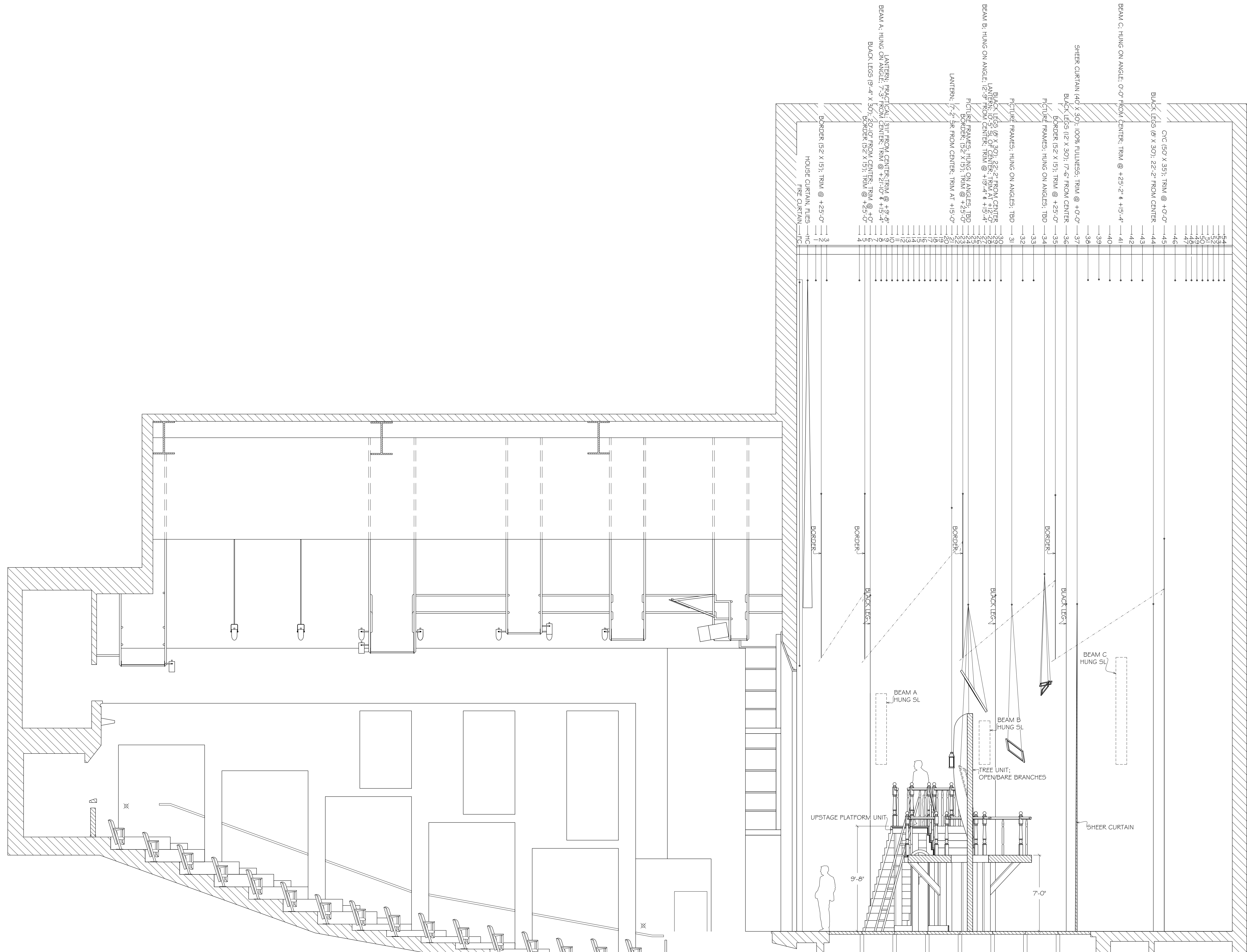

ALL MATERIALS, CONSTRUCTION AND FINISHES MUST COMPLY WITH THE MOST STRINGENT APPLICABLE FEDERAL AND LOCAL SAFETY CODES.
 THIS DRAWING AND ALL THE IDEAS, ARRANGEMENTS, DESIGNS AND PLANS CONTAINED HEREIN OR REPRESENTED THEREBY ARE OWNED AND REMAIN THE PROPERTY OF THE DESIGNER, AND HAVE BEEN CREATED AND DEVELOPED FOR USE ON, AND IN CONNECTION WITH, THE PROJECT SPECIFIED. NEITHER THIS DRAWING, NOR ANY OF SUCH IDEAS, ARRANGEMENTS, DESIGNS OR PLANS SHALL BE APPROPRIATED BY OR DISCLOSED TO ANY PERSON, FIRM OR CORPORATION FOR ANY USE WHATSOEVER, EXCEPT BY SPECIFIC AND WRITTEN PERMISSION OF THE DESIGNER.
 WRITTEN DIMENSIONS ON DRAWINGS SHALL HAVE AUTHORITY OVER SCALED CONSTRUCTORS AND MANUFACTURERS SHALL VERIFY AND BE RESPONSIBLE FOR ALL DIMENSIONS AND CONDITIONS ON THE JOB, AND SHALL INFORM THE DESIGNER OF ALL VARIATIONS FROM DRAWINGS PRIOR TO PERFORMING THE WORK. THE DESIGNER SHALL FIRST SEE AND APPROVE CONTRACTOR'S FULL-SIZE DETAILS BEFORE ANY FABRICATION IS BEGUN.
 THESE DRAWINGS REPRESENT VISUAL CONCEPTS AND CONSTRUCTION SUGGESTIONS ONLY. THE DESIGNER AND HIS/HER EMPLOYEES AND ASSISTANTS ARE NOT QUALIFIED TO DETERMINE THE STRUCTURAL APPROPRIATENESS OF THESE DESIGNS, AND WILL NOT ASSUME RESPONSIBILITY FOR IMPROPER ENGINEERING, CONSTRUCTION AND/OR HANDLING OF THE SCENERY REPRESENTED HEREIN.

SCALE: 1/4" = 1'-0"
 DRWG: RACHEL ROSE BURKE
 DATE: 03/05/2021
 REVISION(S):

DRAWING TITLE
SR CENTERLINE SECTION

SHEET NO.
2

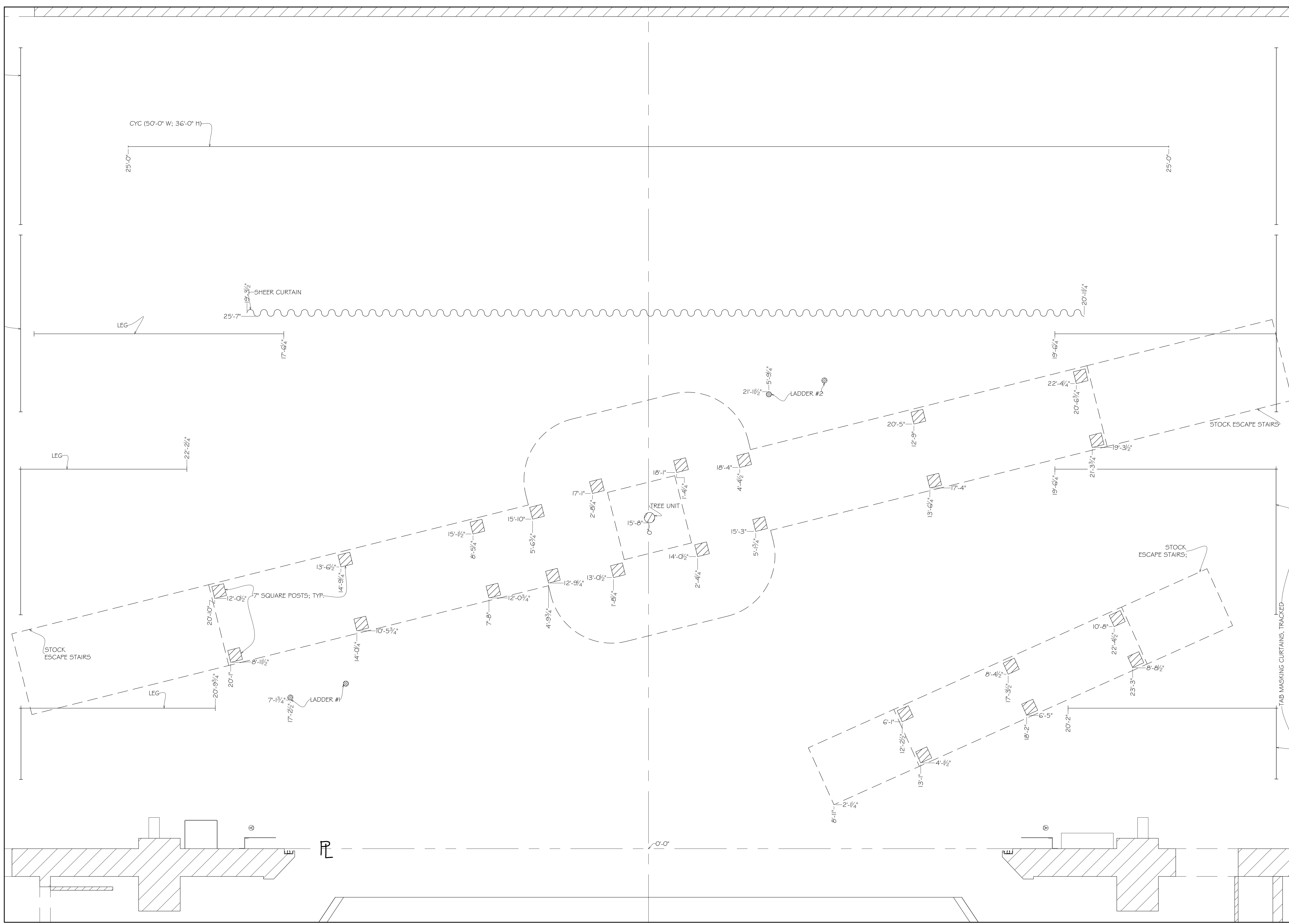

ALL MATERIALS, CONSTRUCTION AND FINISHES MUST COMPLY WITH THE MOST STRINGENT APPLICABLE FEDERAL AND LOCAL SAFETY CODES.
 THIS DRAWING AND ALL THE IDEAS, ARRANGEMENTS, DESIGNS AND PLANS CONTAINED HEREIN OR REPRESENTED THEREBY ARE OWNED AND REMAIN THE PROPERTY OF THE DESIGNER, AND HAVE BEEN CREATED AND DEVELOPED FOR USE ON, AND IN CONNECTION WITH, THE PROJECT SPECIFIED. NEITHER THIS DRAWING, NOR ANY OF SUCH IDEAS, ARRANGEMENTS, DESIGNS OR PLANS SHALL BE REPRODUCED, COPIED, DISCLOSED TO ANY PERSON, FIRM OR CORPORATION FOR ANY USE WHATSOEVER, EXCEPT BY SPECIFIC AND WRITTEN PERMISSION OF THE DESIGNER.
 WRITTEN DIMENSIONS ON DRAWINGS SHALL HAVE AUTHORITY OVER SCALED, CONTRACTORS AND MANUFACTURERS SHALL VERIFY AND BE RESPONSIBLE FOR ALL DIMENSIONS AND CONDITIONS ON THE JOB, AND SHALL INFORM THE DESIGNER OF ALL VARIATIONS FROM DRAWINGS PRIOR TO PERFORMING THE WORK. THE DESIGNER SHALL FIRST SEE AND APPROVE CONTRACTOR'S FULL-SIZE DETAILS BEFORE ANY FABRICATION BEGINS.
 THESE DRAWINGS REPRESENT VISUAL CONCEPTS AND CONSTRUCTION SUGGESTIONS ONLY. THE DESIGNER AND HIS/HER EMPLOYEES AND ASSISTANTS ARE NOT QUALIFIED TO DETERMINE THE STRUCTURAL APPROPRIATENESS OF THESE DECISIONS, AND WILL NOT ASSUME RESPONSIBILITY FOR IMPROPER ENGINEERING, CONSTRUCTION AND/OR HANDLING OF THE SCENERY REPRESENTED HEREIN.

SCALE:	1/2" = 1'-0"
DRWG:	RACHEL ROSE BURKE
DATE:	03/05/2021
REVISION(S):	

DRAWING TITLE
DECK LAYOUT

SHEET NO.
3

- NOTES:
1. RELEVANT DETAIL DRAWINGS AND INFO ON SHEET 5A
 2. LADDER DRAWING ON SHEET 6
 3. TREE UNIT WILL REST IN OPENING TOWARDS THE CENTER OF THE PLATFORM; DRAWING ON SHEET 6

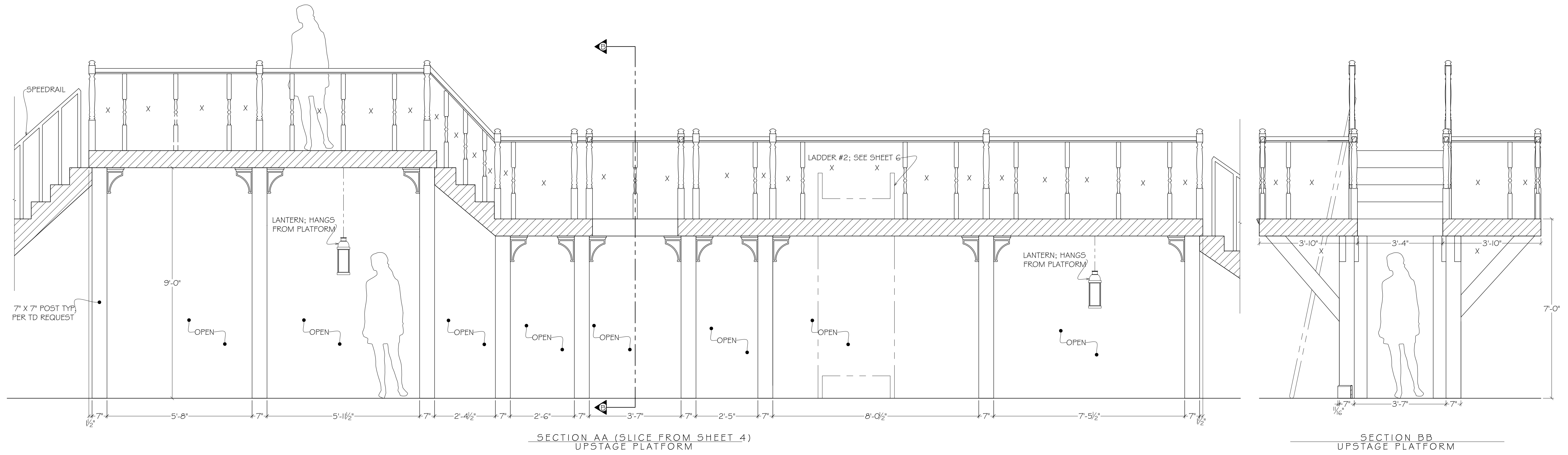

ALL MATERIALS, CONSTRUCTION AND FINISHES MUST COMPLY WITH THE MOST STRINGENT APPLICABLE FEDERAL AND LOCAL SAFETY CODES.
 THIS DRAWING AND ALL THE IDEAS, ARRANGEMENTS, DESIGNS AND PLANS CONTAINED HEREIN OR REPRESENTED THEREBY ARE OWNED AND REMAIN THE PROPERTY OF THE DESIGNER, AND HAVE BEEN CREATED AND DEVELOPED FOR USE ON, AND IN CONNECTION WITH, THE PROJECT SPECIFIED. NEITHER THIS DRAWING, NOR ANY OF SUCH IDEAS, ARRANGEMENTS, DESIGNS OR PLANS SHALL BE APPROPRIATED BY OR DISCLOSED TO ANY PERSON, FIRM OR CORPORATION FOR ANY USE WHATSOEVER, EXCEPT BY SPECIFIC AND WRITTEN PERMISSION OF THE DESIGNER.
 WRITTEN DIMENSIONS ON DRAWINGS SHALL HAVE AUTHORITY OVER SCALED CONSTRUCTION AND MANUFACTURERS SHALL VERIFY AND BE RESPONSIBLE FOR ALL DIMENSIONS AND CONDITIONS ON THE JOB, AND SHALL INFORM THE DESIGNER OF ALL VARIATIONS FROM DRAWINGS PRIOR TO PERFORMING THE WORK. THE DESIGNER SHALL FIRST SEE AND APPROVE CONTRACTOR'S FULL-SIZE DETAILS BEFORE ANY FABRICATION IS BEGUN.
 THESE DRAWINGS REPRESENT VISUAL CONCEPTS AND CONSTRUCTION SUGGESTIONS ONLY. THE DESIGNER AND HIS/HER EMPLOYEES AND ASSISTANTS ARE NOT QUALIFIED TO DETERMINE THE STRUCTURAL APPROPRIATENESS OF THESE DESIGNS, AND WILL NOT ASSUME RESPONSIBILITY FOR IMPROPER ENGINEERING, CONSTRUCTION AND/OR HANDLING OF THE SCENERY REPRESENTED HEREIN.

SCALE: 1/2" = 1'-0"
 DRWG: RACHEL ROSE BURKE
 DATE: 03/05/2021
 REVISION(S):

DRAWING TITLE
**UPSTAGE PLATFORM
SECTION VIEWS**

SHEET NO.
4A

LITTLE
WOMEN

- NOTES:
 1. FRAME IS ATTACHED TO UNDERSIDE OF PLATFORM ON SPECIFIED ANGLE
 2. DETAIL VIEWS ON SHEET 5A

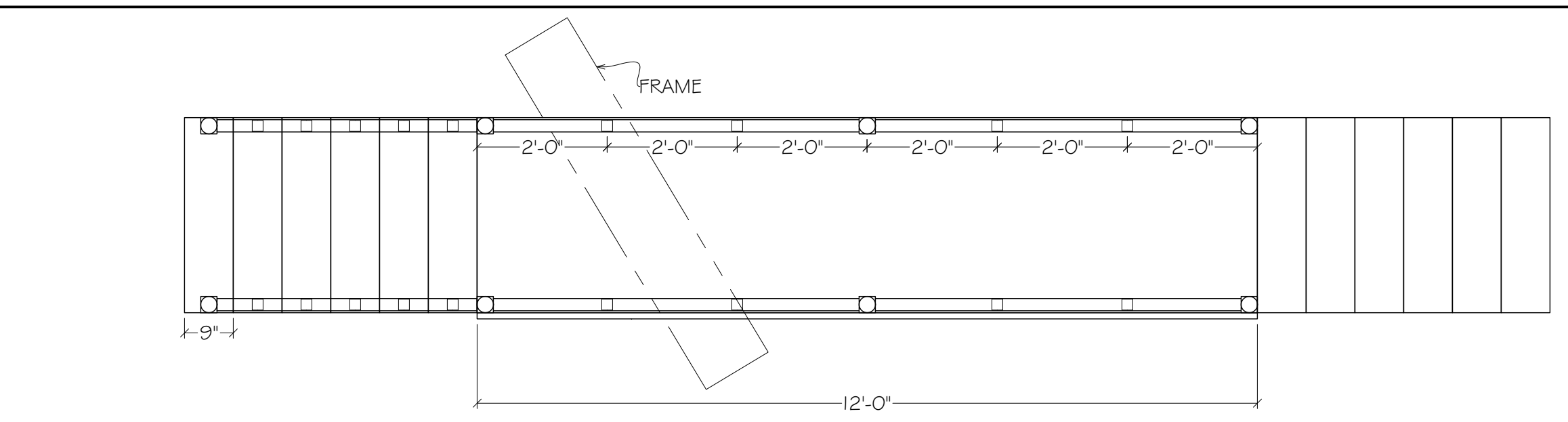

TOP VIEW
DOWNSTAGE PLATFORM

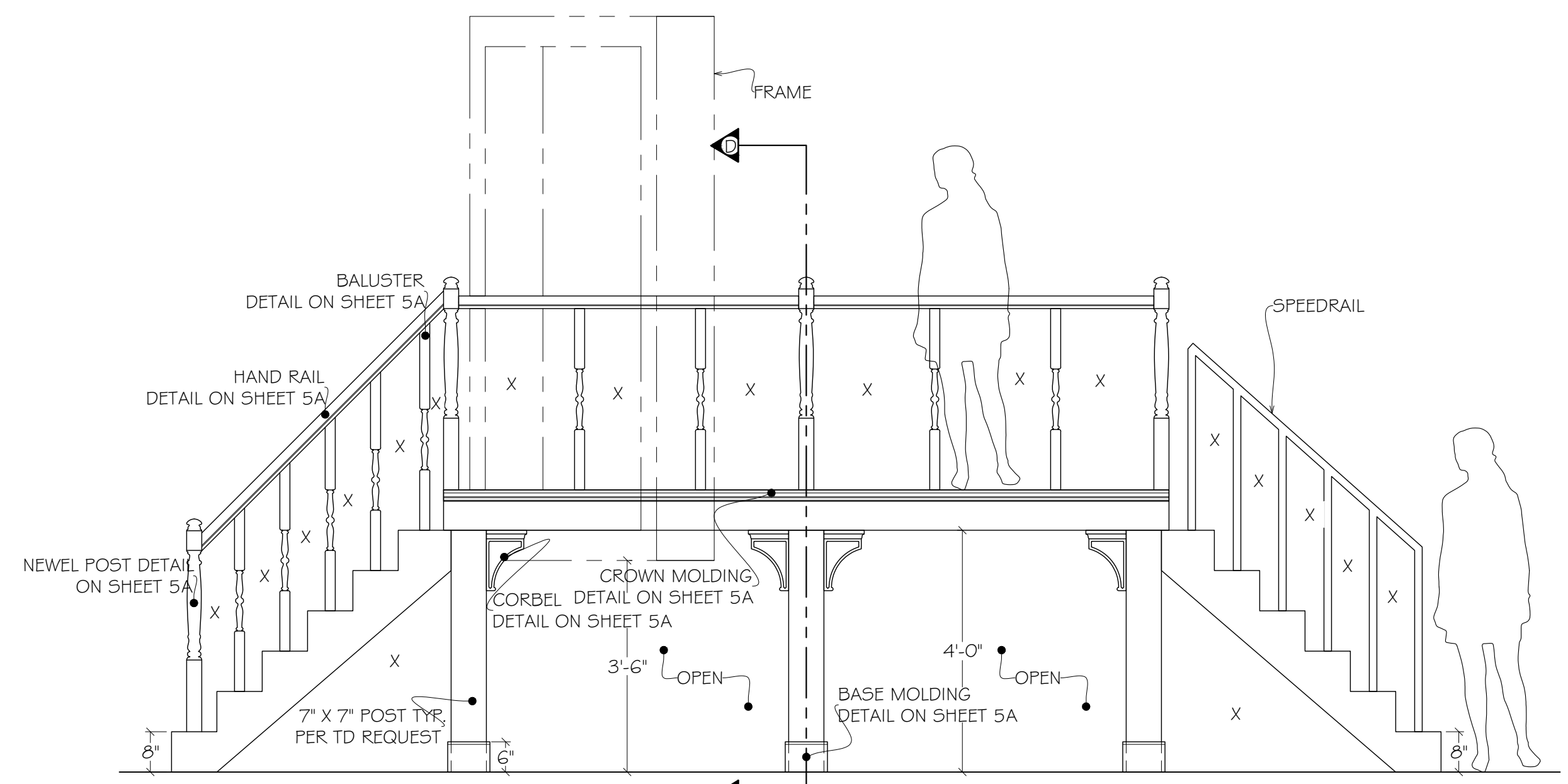

FRONT VIEW
DOWNSTAGE PLATFORM

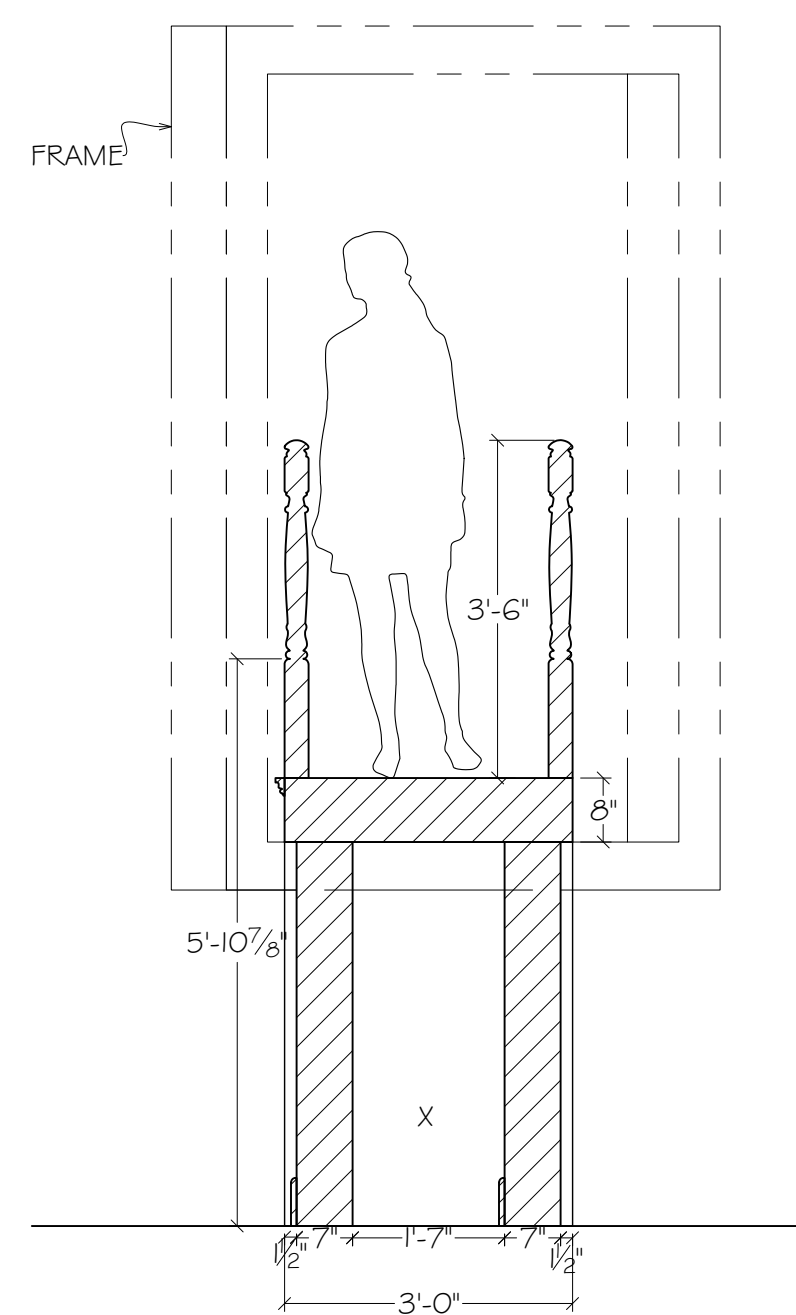

SECTION DD
DOWNSTAGE PLATFORM

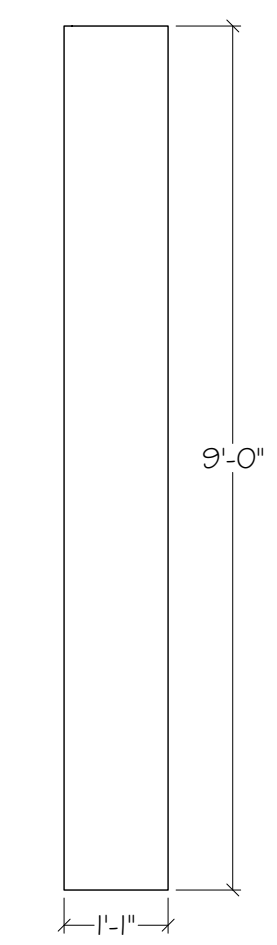

SIDE VIEW
DS SECTION FRAME

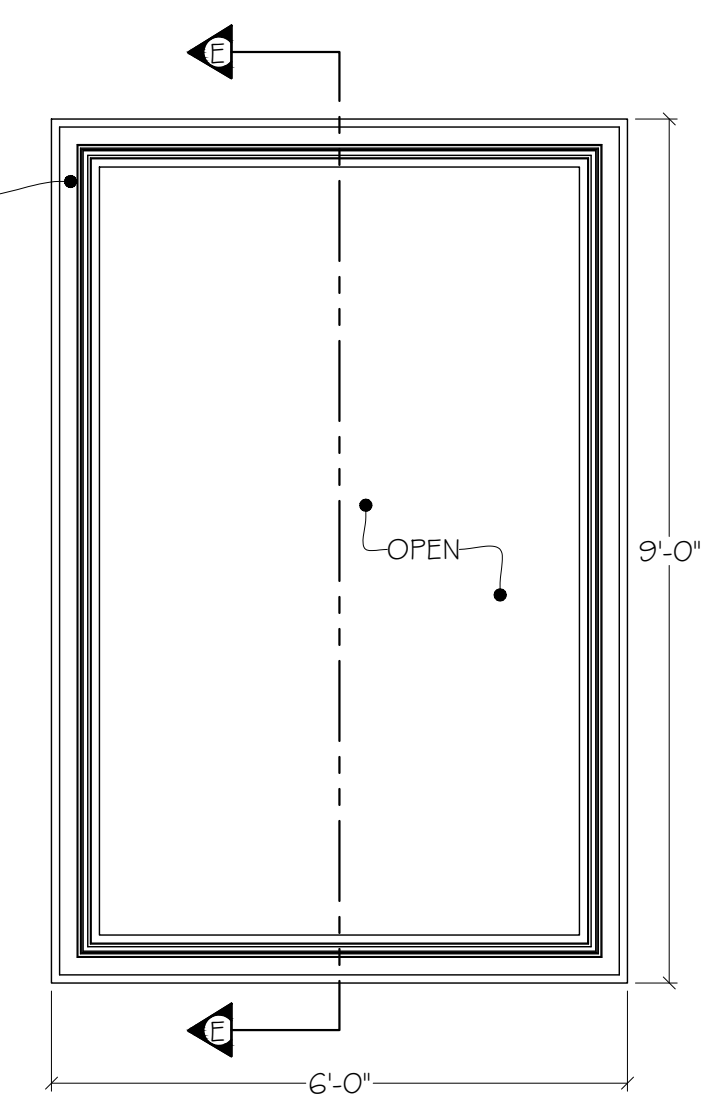

FRONT VIEW
DS PLATFORM FRAME

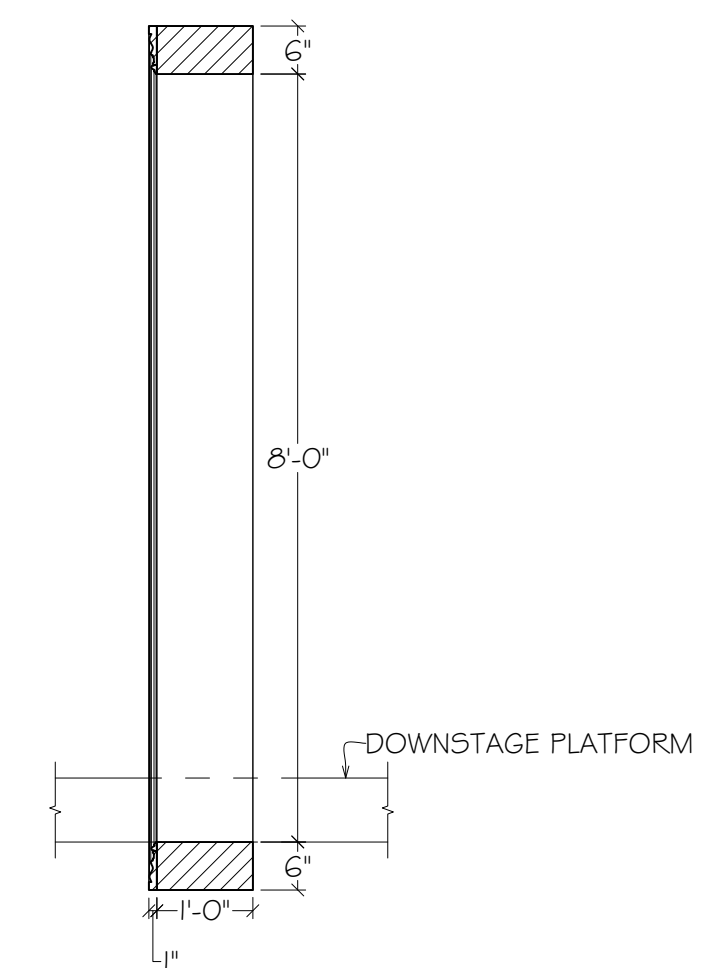

SECTION EE
DS PLATFORM FRAME

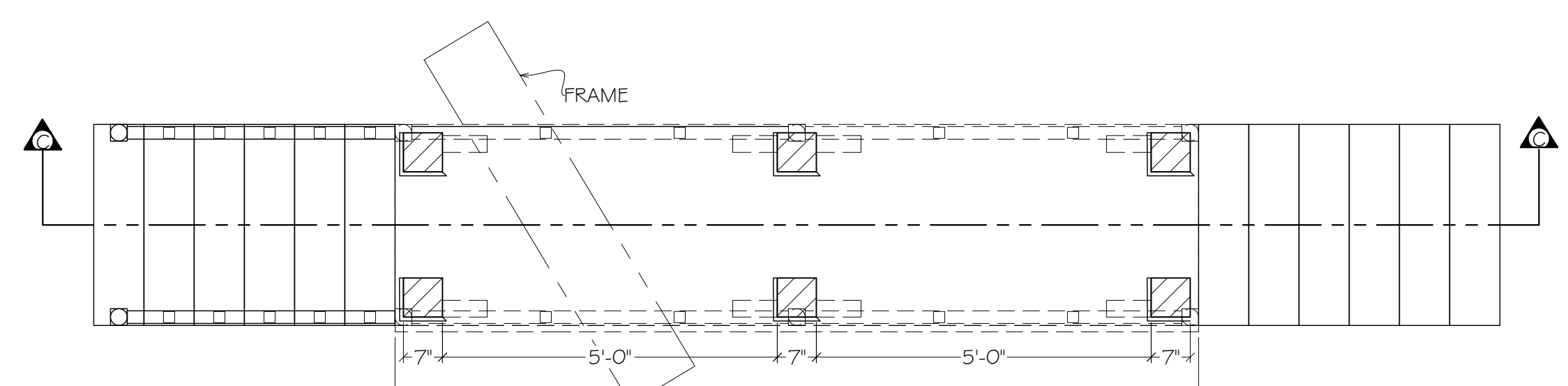

PLAN VIEW
DOWNSTAGE PLATFORM

- NOTES:
 1. HAND RAIL DETAIL ON SHEET 5A
 2. NEWEL POST DETAIL ON SHEET 5A
 3. BALUSTER DETAIL ON SHEET 5A
 4. CROWN DETAIL ON SHEET 5A
 5. CORBEL DETAIL ON SHEET 5A
 6. BASE MOLDING DETAIL ON SHEET 5A

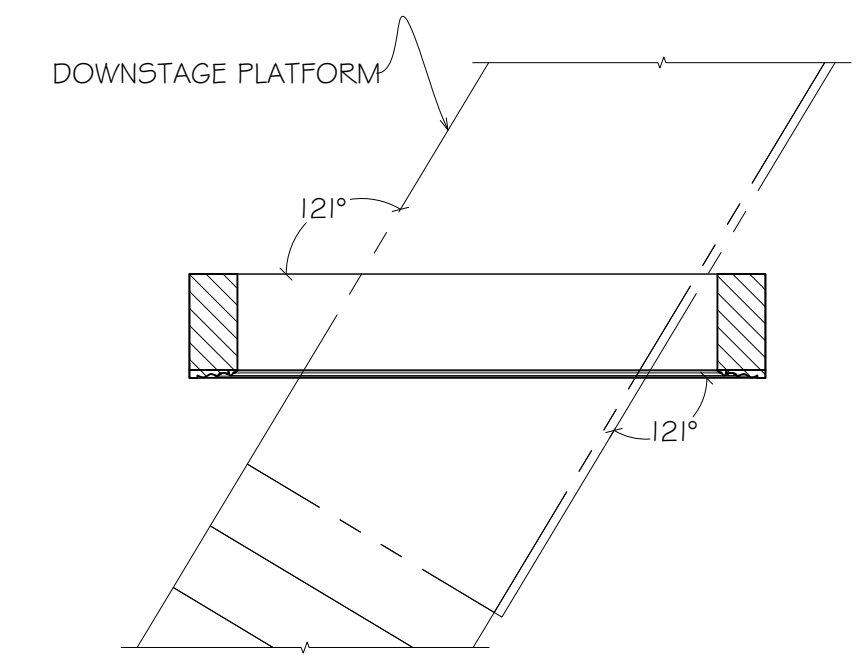

PLAN VIEW
DS PLATFORM FRAME

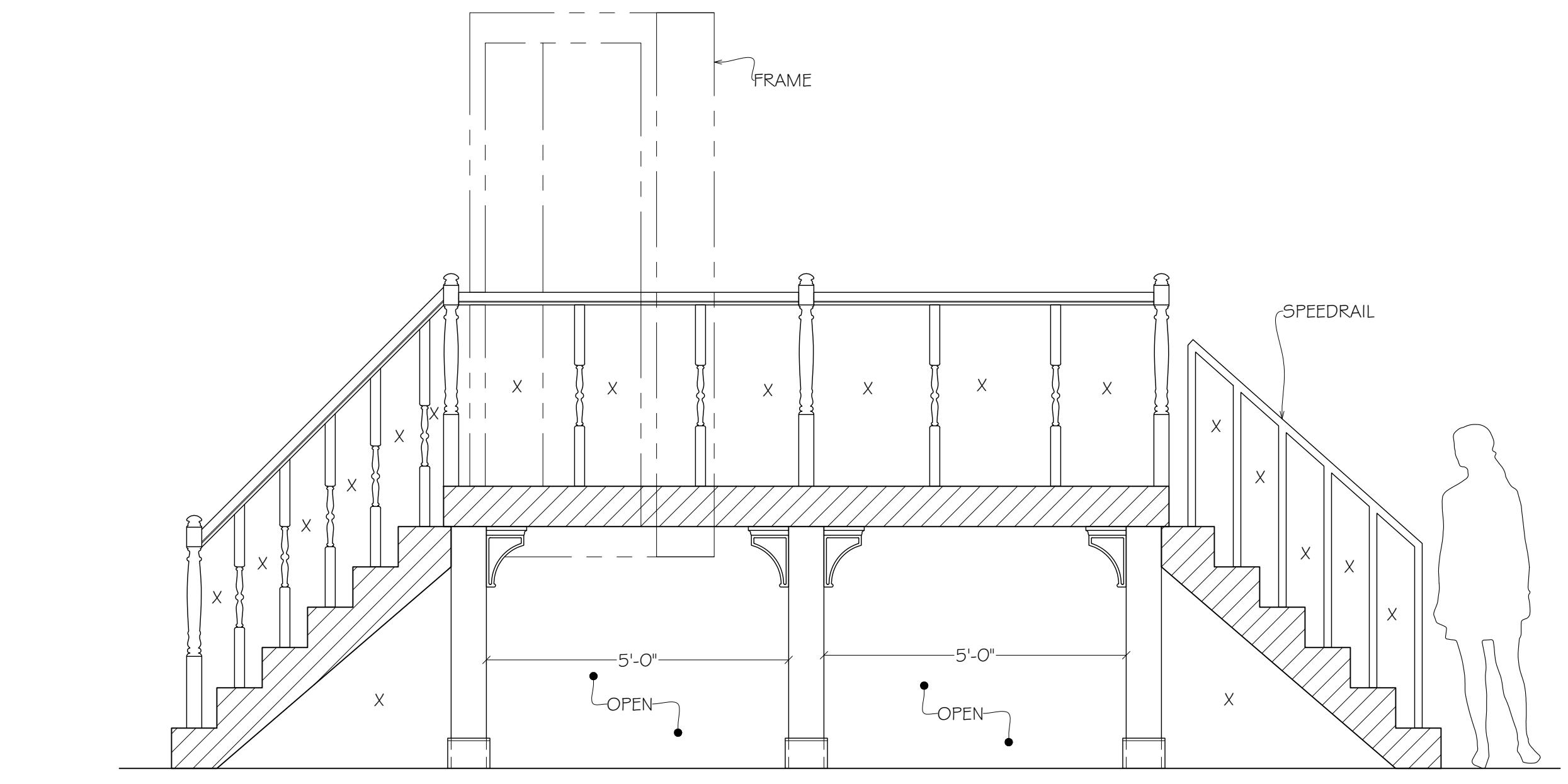

SECTION CC
DOWNSTAGE PLATFORM

ALL MATERIALS, CONSTRUCTION AND FINISHES MUST COMPLY WITH THE MOST STRINGENT APPLICABLE FEDERAL AND LOCAL SAFETY CODES.
 THIS DRAWING AND ALL THE IDEAS, ARRANGEMENTS, DESIGNS AND PLANS CONTAINED HEREIN OR REPRESENTED THEREBY ARE OWNED AND REMAIN THE PROPERTY OF THE DESIGNER, AND HAVE BEEN CREATED AND DEVELOPED FOR USE ON, AND IN CONNECTION WITH, THE PROJECT SPECIFIED. NEITHER THIS DRAWING NOR ANY OF SUCH IDEAS, ARRANGEMENTS, DESIGNS OR PLANS SHALL BE APPROPRIATED BY OR DISCLOSED TO ANY PERSON, FIRM OR CORPORATION FOR ANY USE WHATSOEVER, EXCEPT BY SPECIFIC AND WRITTEN PERMISSION OF THE DESIGNER.
 WRITTEN DIMENSIONS ON DRAWINGS SHALL HAVE AUTHORITY OVER SCALED CONSTRUCTION AND MANUFACTURERS SHALL VERIFY AND BE RESPONSIBLE FOR ALL DIMENSIONS AND CONDITIONS ON THE JOB, AND SHALL INFORM THE DESIGNER OF ALL VARIATIONS FROM DRAWINGS PRIOR TO PERFORMING THE WORK. THE DESIGNER SHALL FIRST SEE AND APPROVE CONTRACTOR'S FULL-SIZE DETAILS BEFORE ANY FABRICATION BEGINS.
 THESE DRAWINGS REPRESENT VISUAL CONCEPTS AND CONSTRUCTION SUGGESTIONS ONLY. THE DESIGNER AND HIS/HER EMPLOYEES AND ASSISTANTS ARE NOT QUALIFIED TO DETERMINE THE STRUCTURAL APPROPRIATENESS OF THESE SUGGESTIONS AND WILL NOT ASSUME RESPONSIBILITY FOR IMPROPER ENGINEERING, CONSTRUCTION AND/OR HANDLING OF THE SCENERY REPRESENTED HEREIN.

SCALE: 1/2" = 1'-0"
 DRWG: RACHEL ROSE BURKE
 DATE: 03/05/2021
 REVISION(S):

DRAWING TITLE
DOWNSTAGE PLATFORM & FRAME

SHEET NO.

NOTES:
 I. DETAIL VIEWS APPLY TO THE SHEETS 4,4A, # 5

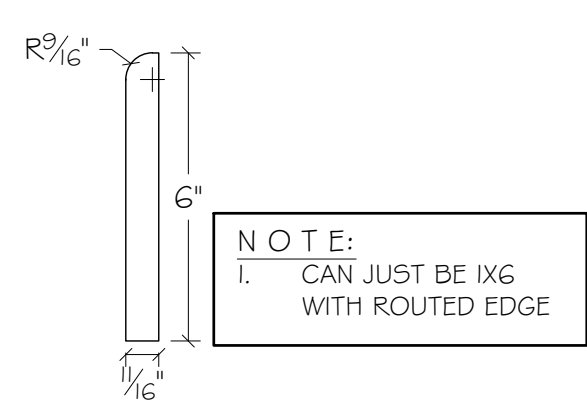

DETAIL VIEW
 BASE MOLDING
 SCALE: 3"=1'-0"

NOTE:
 I. CAN JUST BE IMG WITH ROUTED EDGE

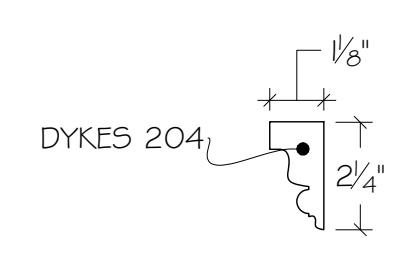

DETAIL VIEW
 CROWN MOLDING
 SCALE: 3"=1'-0"

DYKES 204

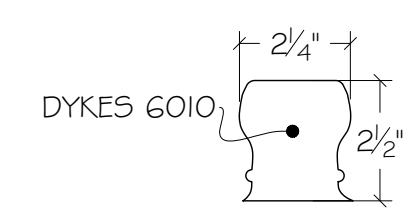

DETAIL VIEW
 HAND RAIL
 SCALE: 3"=1'-0"

DYKES 6010

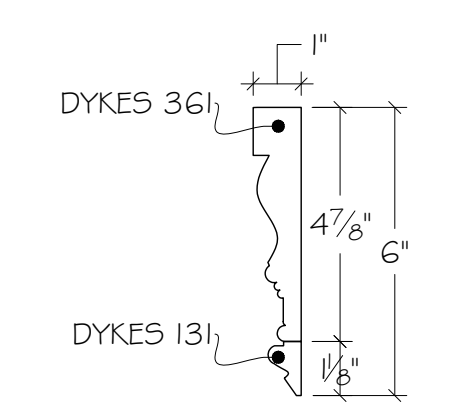

DETAIL VIEW
 FRAME CASE MOLDING
 SCALE: 3"=1'-0"

DYKES 361

DYKES 131

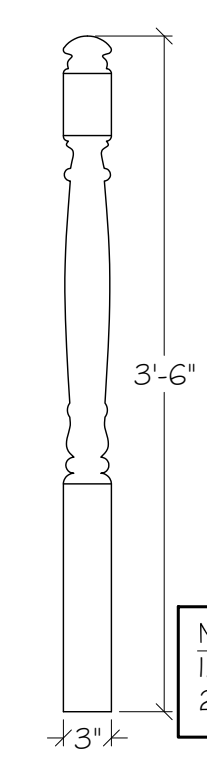

DETAIL VIEW
 NEWEL POST
 SCALE: 1"=1'-0"

NOTE:
 1. LOWES ITEM #1930767
 2. MODEL #RO-4040

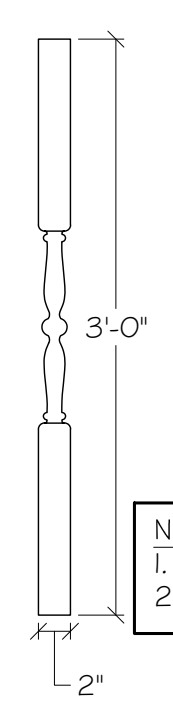

DETAIL VIEW
 BALUSTER
 SCALE: 1"=1'-0"

NOTE:
 1. LOWES ITEM #488993
 2. MODEL #S36COLT15E6

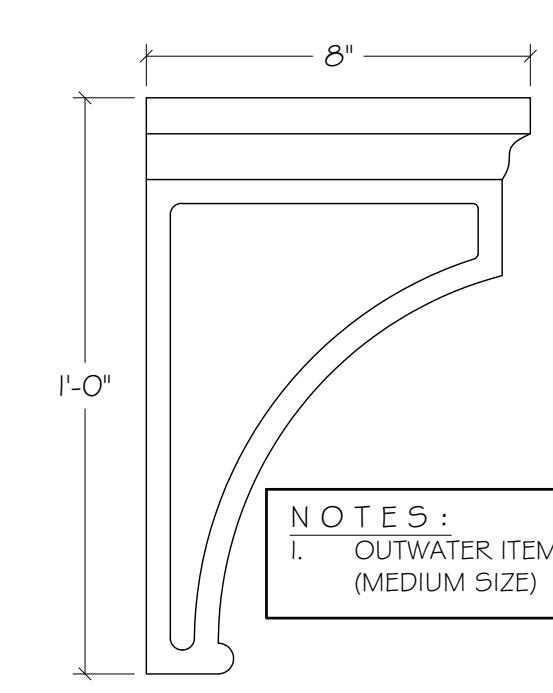

DETAIL VIEW
 CORBEL
 SCALE: 3"=1'-0"

NOTES:
 1. OUTWATER ITEM #22-RWC925 (MEDIUM SIZE)

ALL MATERIALS, CONSTRUCTION AND FINISHES MUST COMPLY WITH THE MOST STRINGENT APPLICABLE FEDERAL AND LOCAL SAFETY CODES.
 THIS DRAWING AND ALL THE IDEAS, ARRANGEMENTS, DESIGNS AND PLANS CONTAINED HEREIN OR REPRESENTED THEREBY ARE OWNED AND REMAIN THE PROPERTY OF THE DESIGNER, AND HAVE BEEN CREATED AND DEVELOPED FOR USE ON, AND IN CONNECTION WITH, THE PROJECT SPECIFIED. NEITHER THIS DRAWING NOR ANY OF SUCH IDEAS, ARRANGEMENTS, DESIGNS OR PLANS SHALL BE APPROPRIATED BY OR DISCLOSED TO ANY PERSON, FIRM OR CORPORATION FOR ANY USE WHATSOEVER, EXCEPT BY SPECIFIC AND WRITTEN PERMISSION OF THE DESIGNER.
 WRITTEN DIMENSIONS ON DRAWINGS SHALL HAVE AUTHORITY OVER SCALED. CONTRACTORS AND MANUFACTURERS SHALL VERIFY AND BE RESPONSIBLE FOR ALL DIMENSIONS AND CONDITIONS ON THE JOB, AND SHALL INFORM THE DESIGNER OF ALL VARIATIONS FROM DRAWINGS PRIOR TO PERFORMING THE WORK. THE DESIGNER SHALL FIRST SEE AND APPROVE CONTRACTOR'S FULL-SIZE DETAILS BEFORE ANY FABRICATION IS BEGUN.
 THESE DRAWINGS REPRESENT VISUAL CONCEPTS AND CONSTRUCTION SUGGESTIONS ONLY. THE DESIGNER AND HIS/HER EMPLOYEES AND ASSISTANTS ARE NOT QUALIFIED TO DETERMINE THE STRUCTURAL APPROPRIATENESS OF THESE DECISIONS, AND WILL NOT ASSUME RESPONSIBILITY FOR IMPROPER ENGINEERING, CONSTRUCTION AND/OR HANDLING OF THE SCENERY REPRESENTED HEREIN.

SCALE: AS NOTED
 DRWG: RACHEL ROSE BURKE
 DATE: 03/05/2021
 REVISION(S):

DRAWING TITLE
DETAIL VIEWS

SHEET NO.
5A

LITTLE
the
WOMEN

NOTES:
 I. TREE MUST BE ABLE TO FIT AND STAND INSIDE THE OPENING IN THE UPSTAGE PLATFORM (SEE SHEET 4)

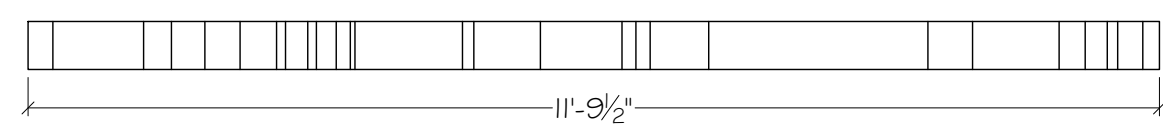

TOP VIEW
TREE UNIT

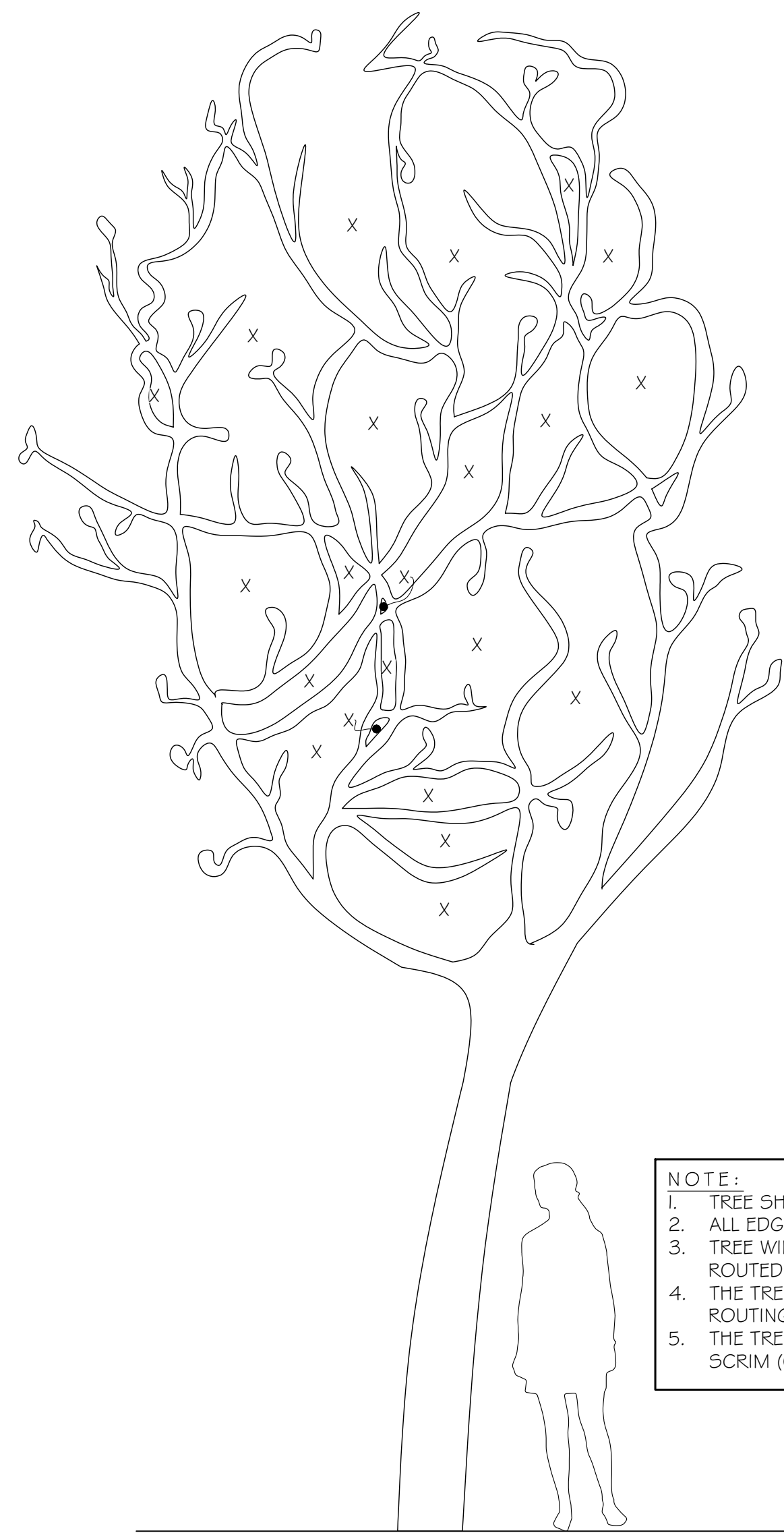

FRONT VIEW
TREE UNIT

NOTE:
 1. TREE SHOULD BE CNC ROUTED OUT OF FOAM
 2. ALL EDGES SHOULD BE SOFTENED
 3. TREE WILL HAVE LED TAPE INSERTED INTO ROUTED PATH ALONG THE SURFACE OF THE TREE
 4. THE TREE SHOULD BE PAINTED BETWEEN ROUTING AND INSETTING THE LED TAPE
 5. THE TREE WILL THEN BE WRAPPED IN BLACK SCRIM (OR COMPARATIVE DIFFUSING MATERIAL)

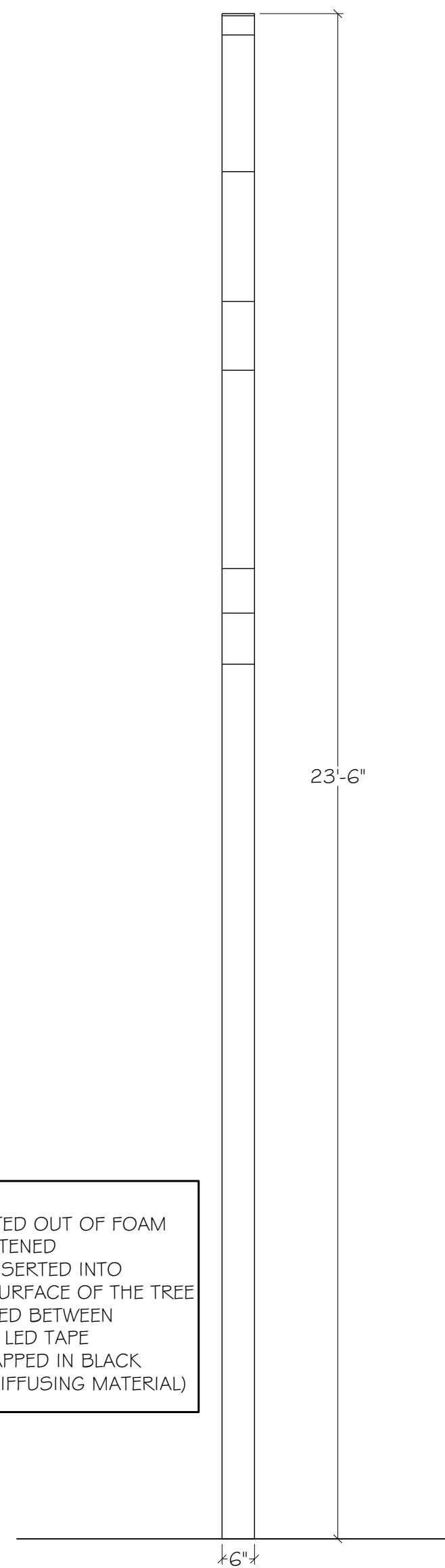

SIDE VIEW
TREE UNIT

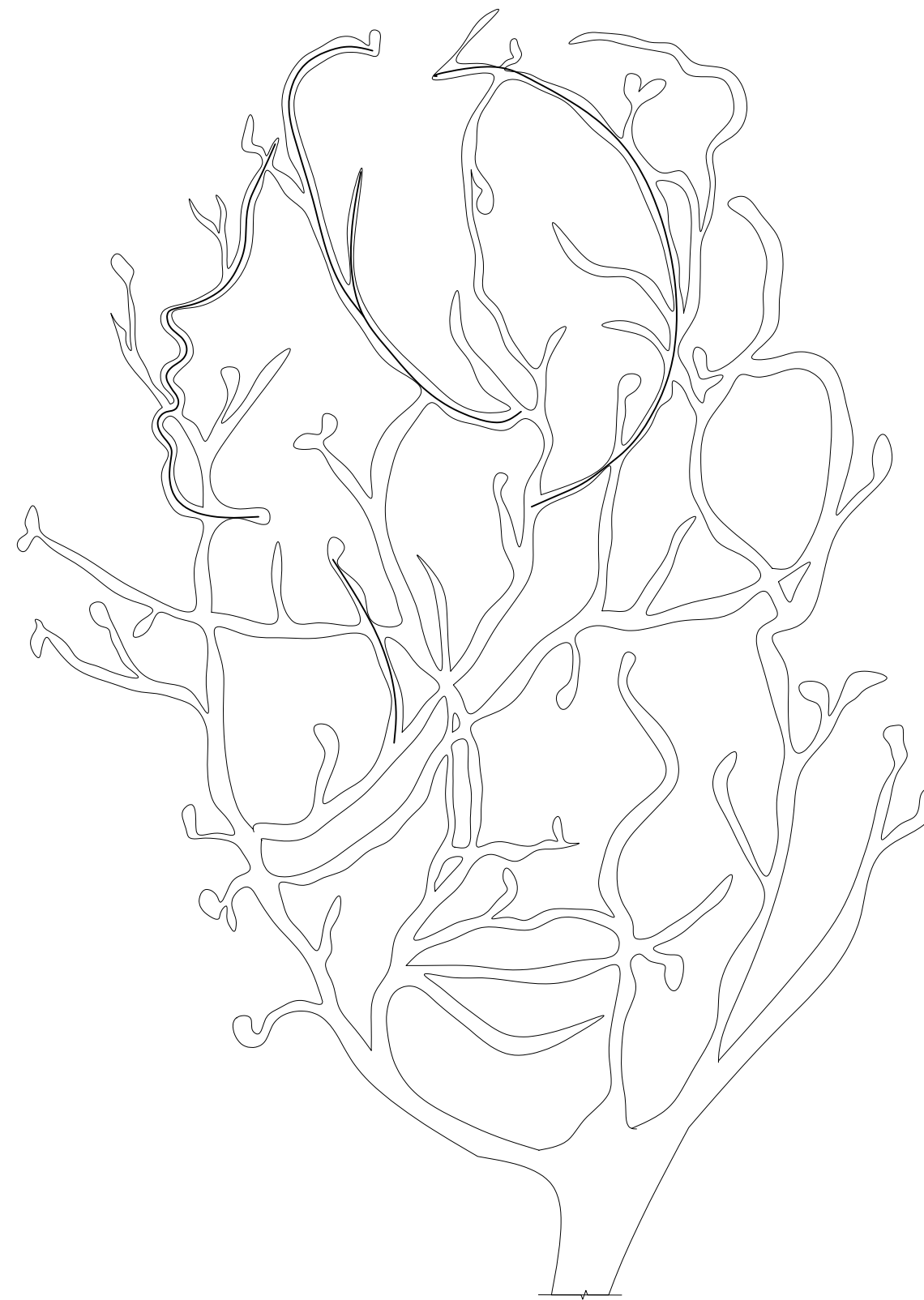

LED TAPE PLACEMENT
IMAGE #1

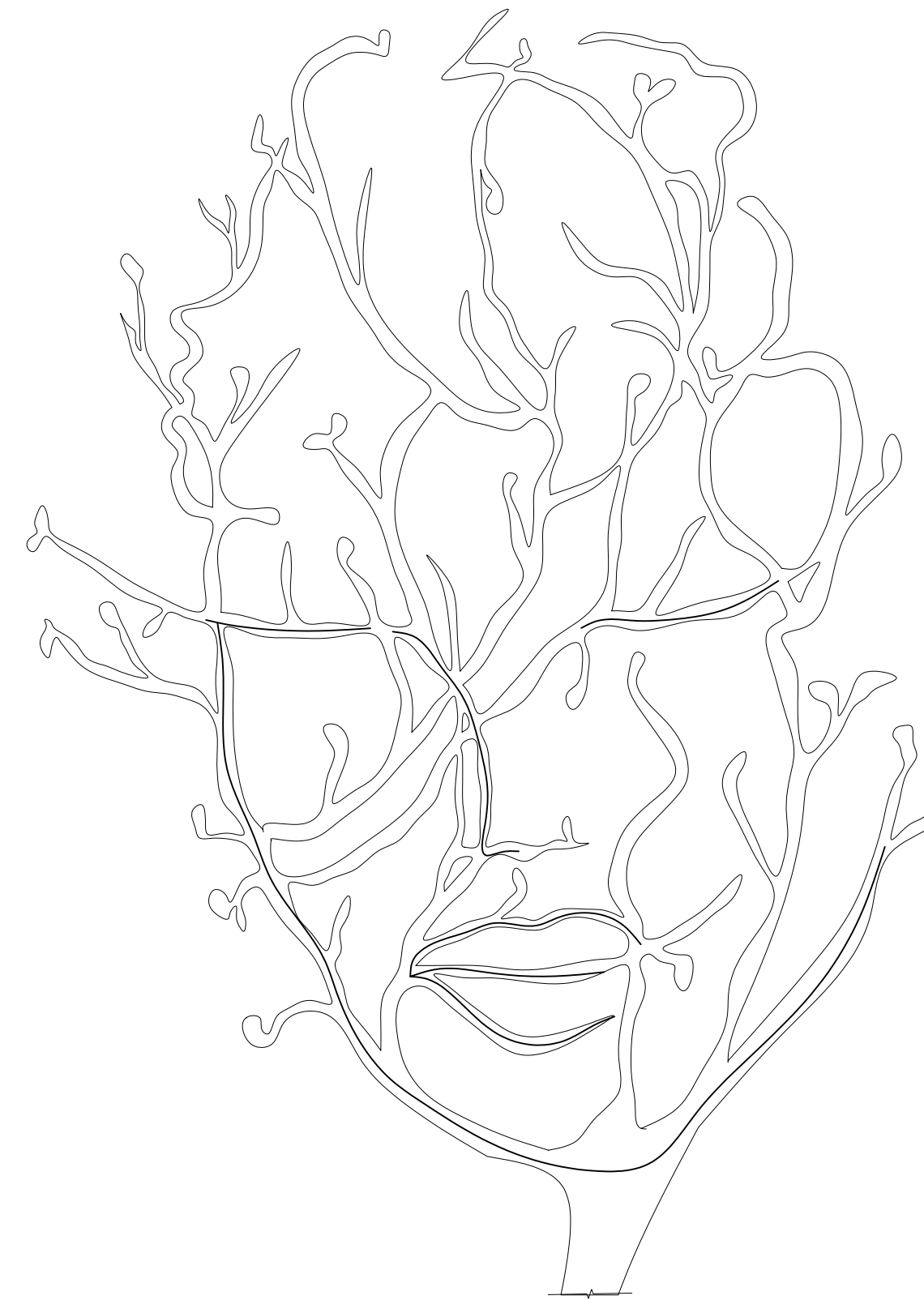

LED TAPE PLACEMENT
IMAGE #2



LED TAPE PLACEMENT
IMAGE #3

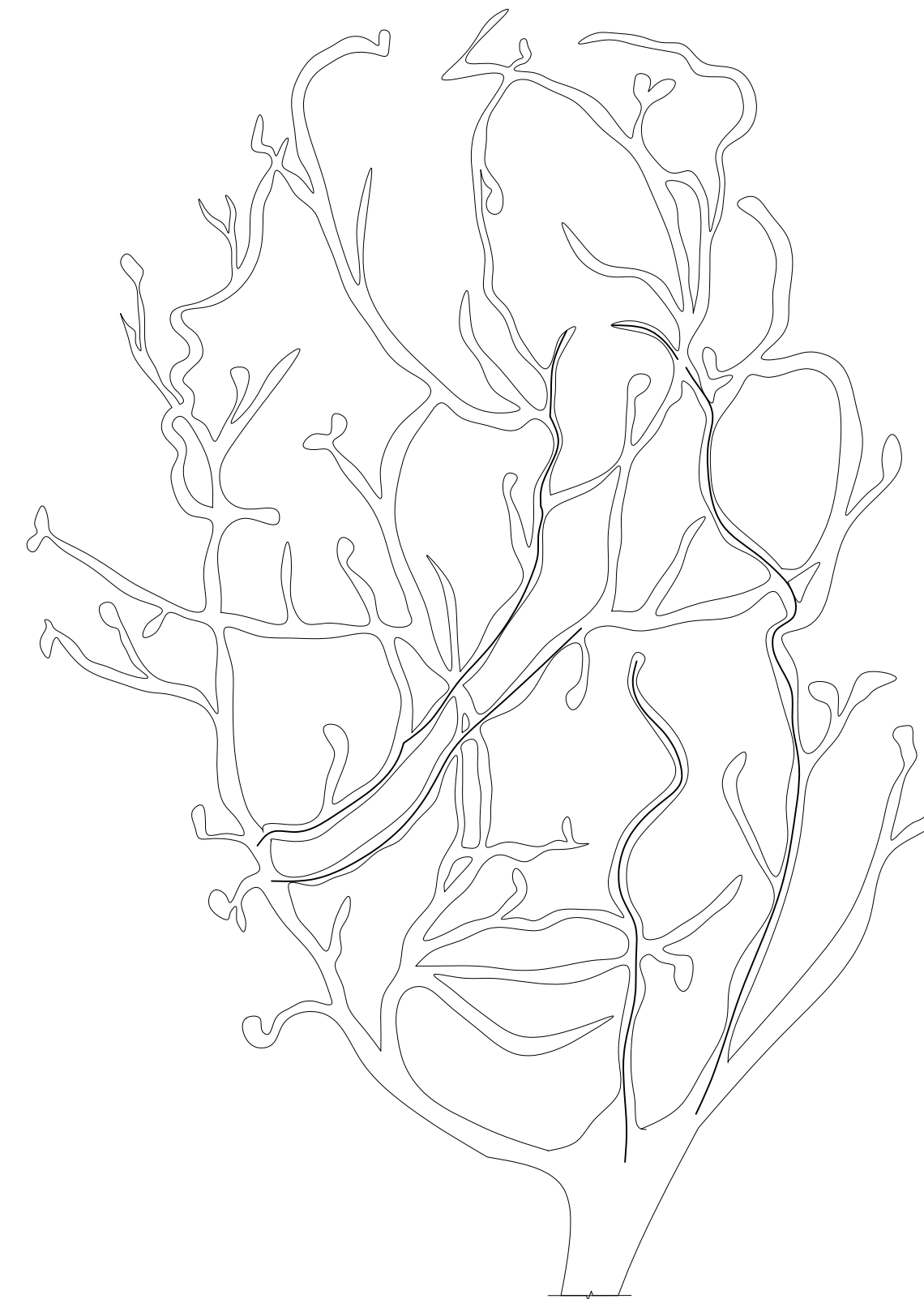

LED TAPE PLACEMENT
IMAGE #4

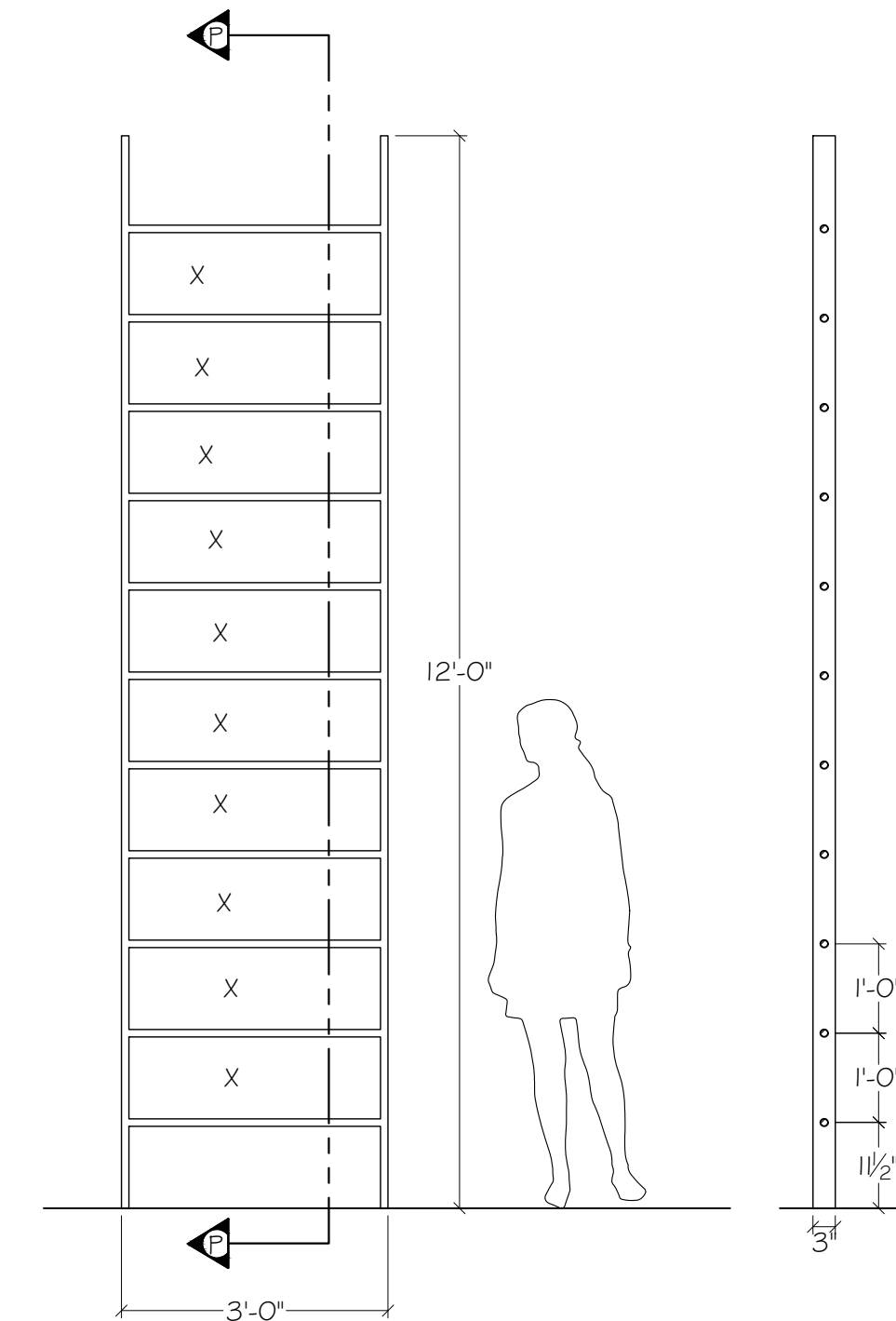

FRONT VIEW
US PLATFORM LADDER #1 SECTION PP
US PLATFORM LADDER #1

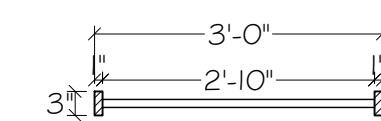

PLAN VIEW
US PLATFORM LADDER #1

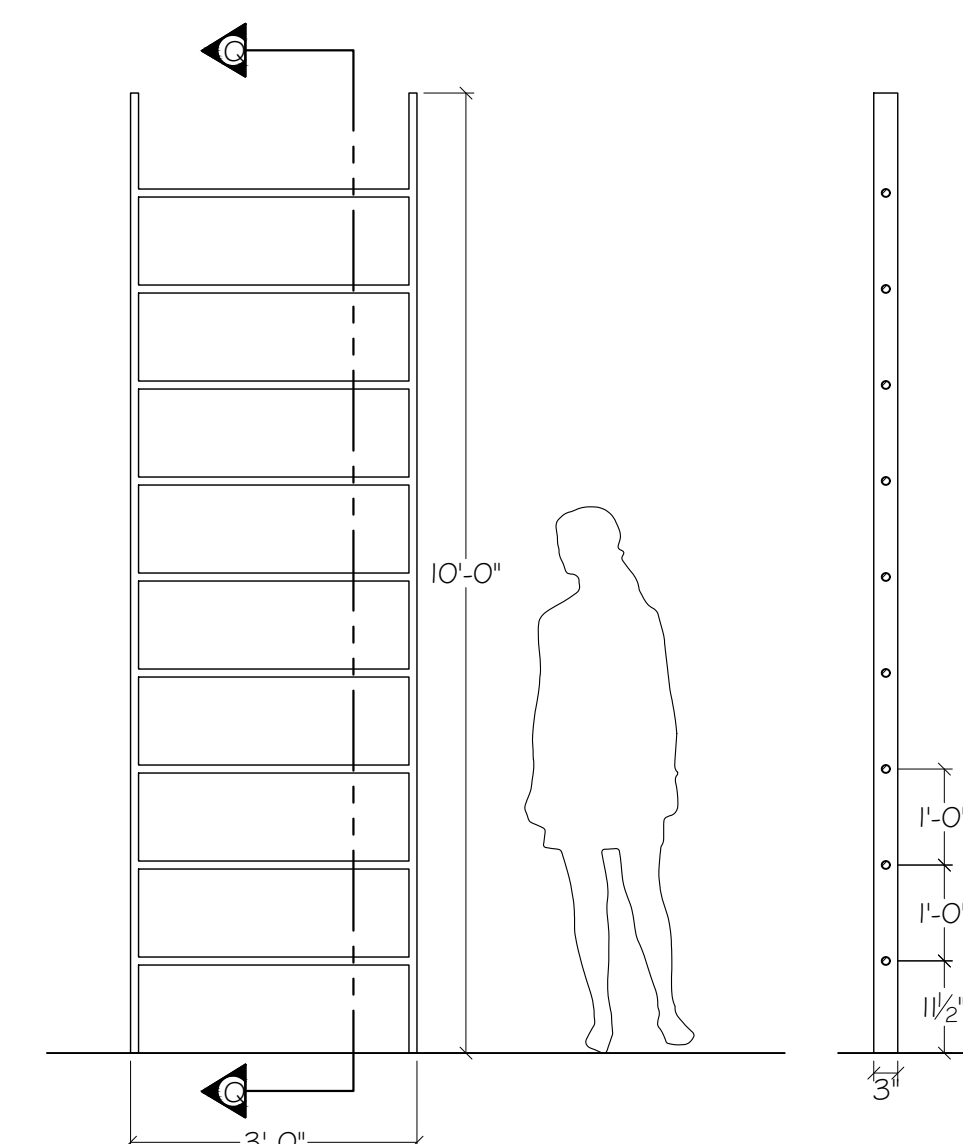

FRONT VIEW
US PLATFORM LADDER #2 SECTION QQ
US PLATFORM LADDER #2

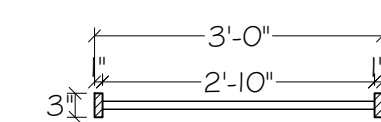

PLAN VIEW
US PLATFORM LADDER #2

ALL MATERIALS, CONSTRUCTION AND FINISHES MUST COMPLY WITH THE MOST STRINGENT APPLICABLE FEDERAL AND LOCAL SAFETY CODES.
 THIS DRAWING AND ALL THE IDEAS, ARRANGEMENTS, DESIGNS AND PLANS CONTAINED HEREIN OR REPRESENTED THEREBY ARE OWNED AND REMAIN THE PROPERTY OF THE DESIGNER, AND HAVE BEEN CREATED AND DEVELOPED FOR USE ON, AND IN CONNECTION WITH, THE PROJECT SPECIFIED. NEITHER THIS DRAWING NOR ANY OF SUCH IDEAS, ARRANGEMENTS, DESIGNS OR PLANS SHALL BE APPROPRIATED BY OR DISCLOSED TO ANY PERSON, FIRM OR CORPORATION FOR ANY USE WHATSOEVER, EXCEPT BY SPECIFIC AND WRITTEN PERMISSION OF THE DESIGNER.
 WRITTEN DIMENSIONS ON DRAWINGS SHALL HAVE AUTHORITY OVER SCALED. CONTRACTORS AND MANUFACTURERS SHALL VERIFY AND BE RESPONSIBLE FOR ALL DIMENSIONS AND CONDITIONS ON THE JOB, AND SHALL INFORM THE DESIGNER OF ALL VARIATIONS FROM DRAWINGS PRIOR TO PERFORMING THE WORK. THE DESIGNER SHALL FIRST SEE AND APPROVE CONTRACTOR'S FULL-SIZE DETAILS BEFORE ANY FABRICATION IS BEGUN.
 THESE DRAWINGS REPRESENT VISUAL CONCEPTS AND CONSTRUCTION SUGGESTIONS ONLY. THE DESIGNER AND HIS/HER EMPLOYEES AND ASSISTANTS ARE NOT QUALIFIED TO DETERMINE THE STRUCTURAL APPROPRIATENESS OF THESE DECISIONS, AND WILL NOT ASSUME RESPONSIBILITY FOR IMPROPER ENGINEERING, CONSTRUCTION AND/OR HANDLING OF THE SCENERY REPRESENTED HEREIN.

SCALE: 1/2" = 1'-0"
 DRWG: RACHEL ROSE BURKE
 DATE: 03/05/2021
 REVISION(S):

DRAWING TITLE
TREE UNIT & US PLATFORM LADDERS

SHEET NO.

- NOTES:**
1. BUILD 2 WINDOW UNITS
 2. WINDOW UNITS WILL BE DEAD HUNG FROM GRID
 3. BEAM A IS HUNG ON LINESET 8; 7'-3" SL FROM CENTER; ONSTAGE TRIM @ +2'-10"; OFFSTAGE TRIM @ +15'-4"
 4. BEAM B IS HUNG ON LINESET 27; 12'-9" SL FROM CENTER; ONSTAGE TRIM @ +19'-4"; OFFSTAGE TRIM @ +15'-4"
 5. BEAM C IS HUNG ON LINESET 41; 0'-0" SL FROM CENTER; ONSTAGE TRIM @ +25'-2"; OFFSTAGE TRIM @ +15'-4"

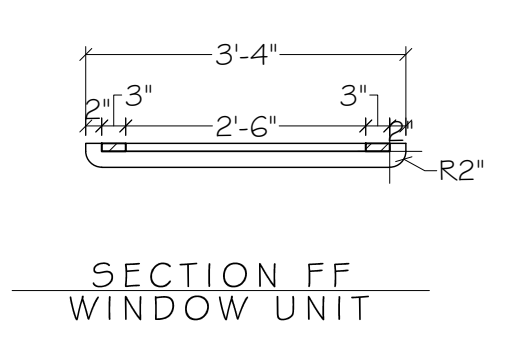
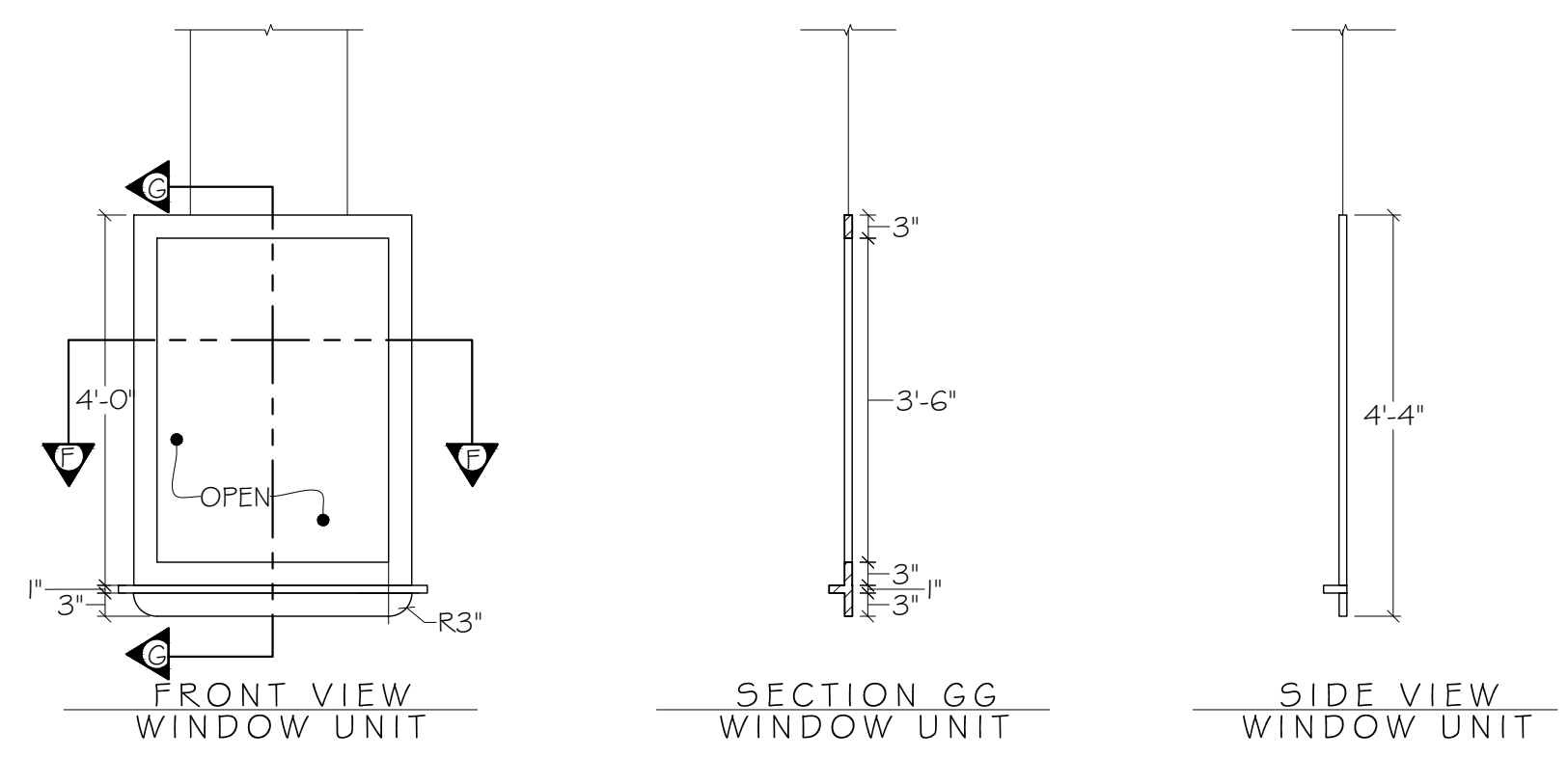

NOTE:
1. BUILD 2

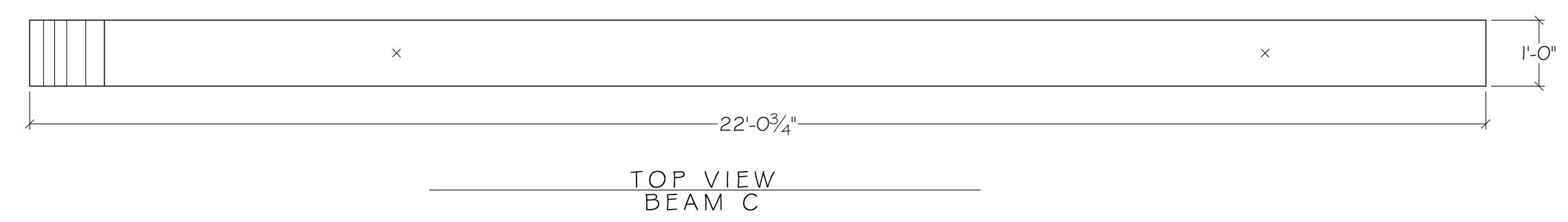
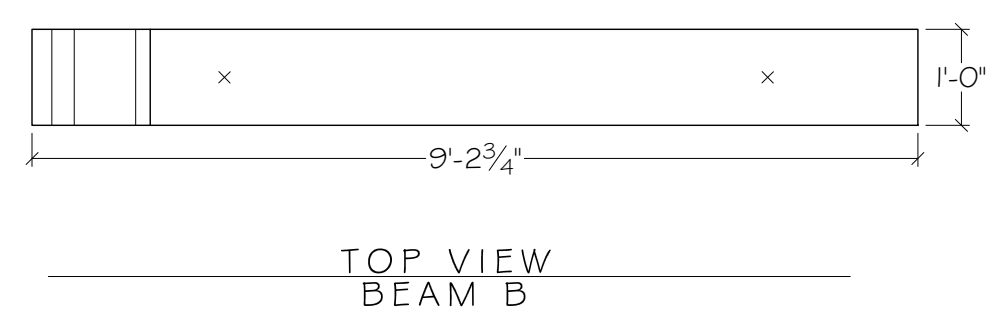
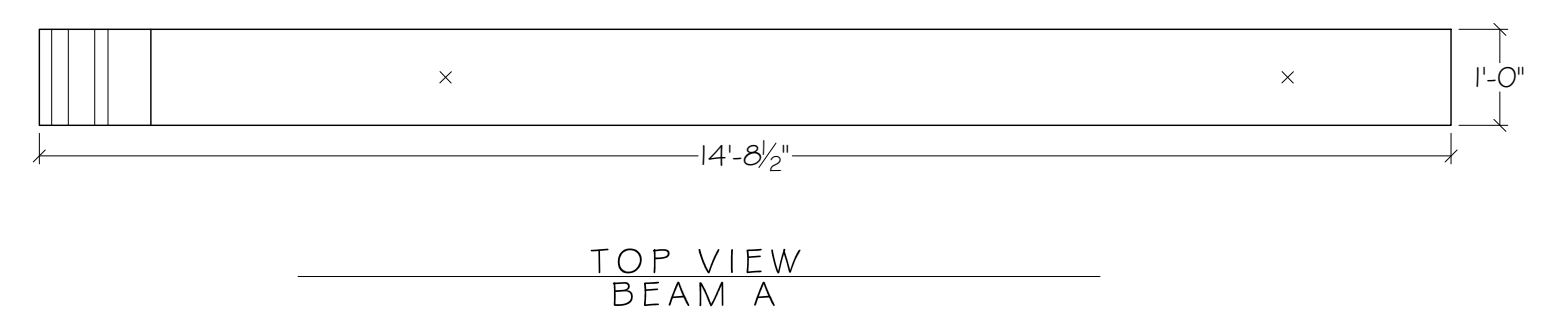

- NOTES:**
1. ADJUST RIGGING POINTS AS NEEDED
 2. JAGGED END DOES NOT NEED TO BE EXACT—JUST SIMILAR

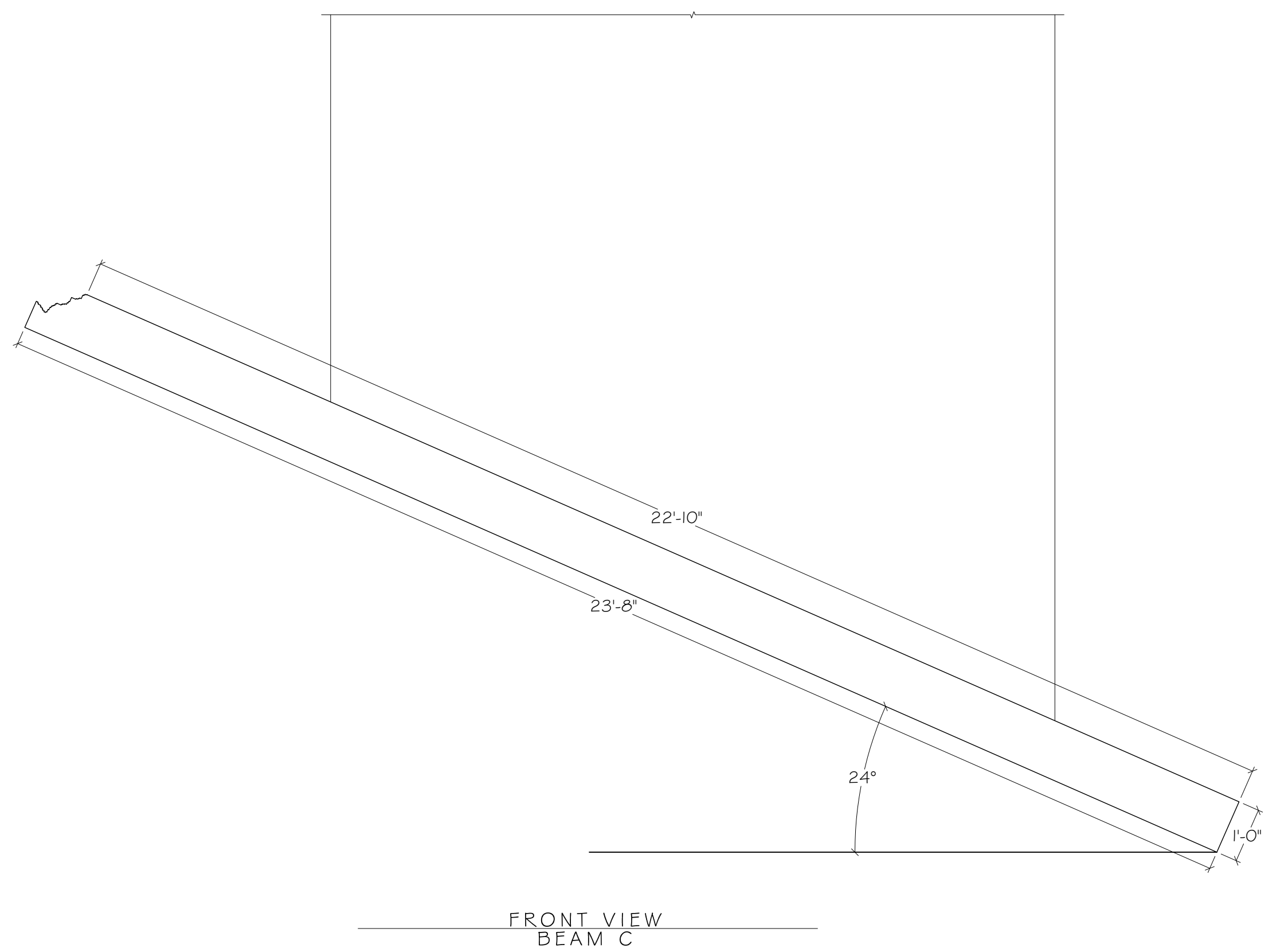
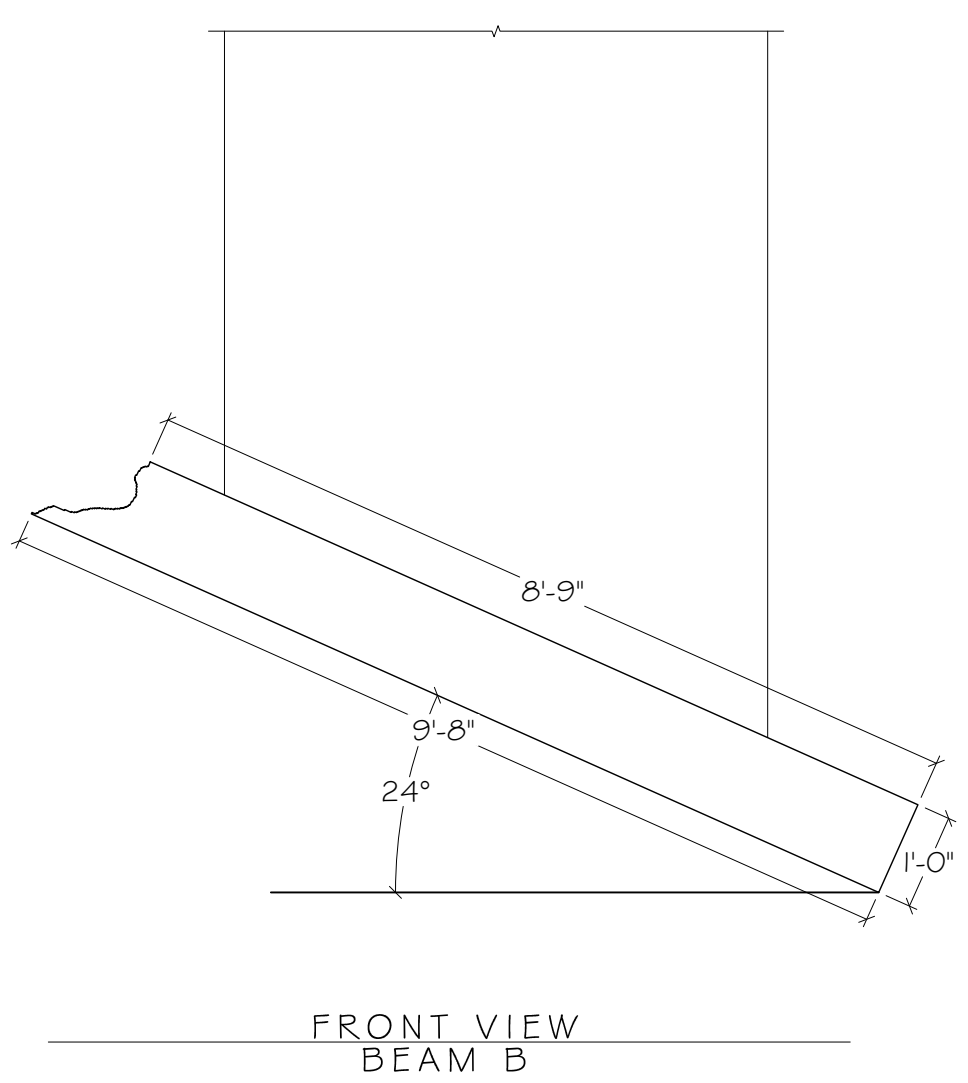
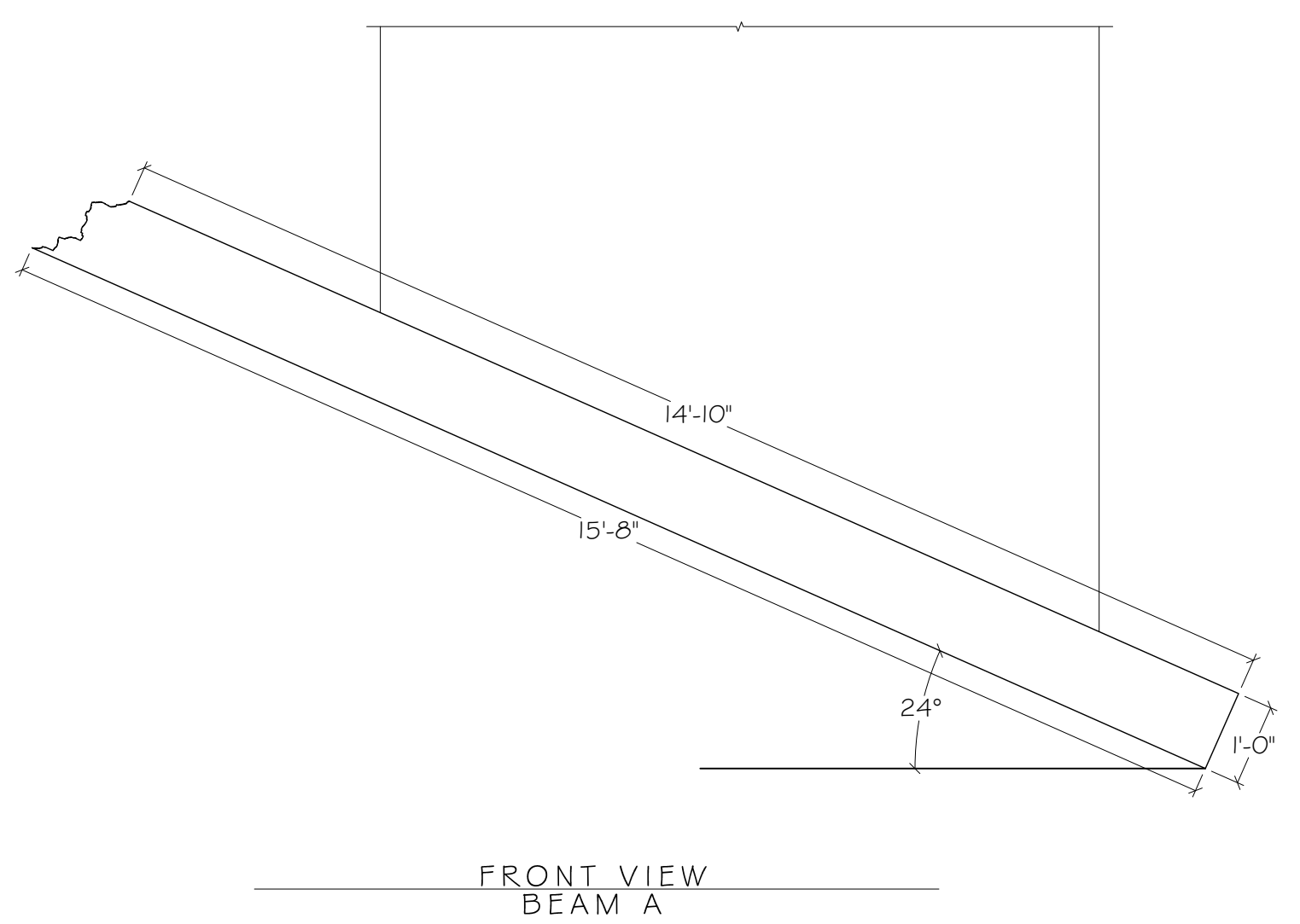

ALL MATERIALS, CONSTRUCTION AND FINISHES MUST COMPLY WITH THE MOST STRINGENT APPLICABLE FEDERAL AND LOCAL SAFETY CODES.

THIS DRAWING AND ALL THE IDEAS, ARRANGEMENTS, DESIGNS AND PLANS CONTAINED HEREIN OR REPRESENTED THEREBY ARE OWNED AND REMAIN THE PROPERTY OF THE DESIGNER, AND HAVE BEEN CREATED AND DEVELOPED FOR USE ON, AND IN CONNECTION WITH, THE PROJECT SPECIFIED. NEITHER THIS DRAWING, NOR ANY OF SUCH IDEAS, ARRANGEMENTS, DESIGNS OR PLANS SHALL BE APPROPRIATED BY OR DISCLOSED TO ANY PERSON, FIRM OR CORPORATION FOR ANY USE WHATSOEVER, EXCEPT BY SPECIFIC AND WRITTEN PERMISSION OF THE DESIGNER.

WRITTEN DIMENSIONS ON DRAWINGS SHALL HAVE AUTHORITY OVER SCALED DIMENSIONS AND MANUFACTURERS SHALL VERIFY AND BE RESPONSIBLE FOR ALL DIMENSIONS AND CONDITIONS ON THE JOB, AND SHALL INFORM THE DESIGNER OF ALL VARIATIONS FROM DRAWINGS PRIOR TO PERFORMING THE WORK. THE DESIGNER SHALL FIRST SEE AND APPROVE CONTRACTOR'S FULL-SIZE DETAILS BEFORE ANY FABRICATION IS BEGUN.

THESE DRAWINGS REPRESENT VISUAL CONCEPTS AND CONSTRUCTION SUGGESTIONS ONLY. THE DESIGNER AND HIS/HER EMPLOYEES AND ASSISTANTS ARE NOT QUALIFIED TO DETERMINE THE STRUCTURAL APPROPRIATENESS OF THESE SUGGESTIONS, AND WILL NOT ASSUME RESPONSIBILITY FOR IMPROPER ENGINEERING, CONSTRUCTION AND/OR HANDLING OF THE SCENERY REPRESENTED HEREIN.

SCALE: 1/2" = 1'-0"
DRWG: RACHEL ROSE BURKE
DATE: 03/05/2021
REVISION(S):

DRAWING TITLE
BEAMS & WINDOW FRAMES

SHEET NO.

LITTLE
the Broadway musical
WOMEN

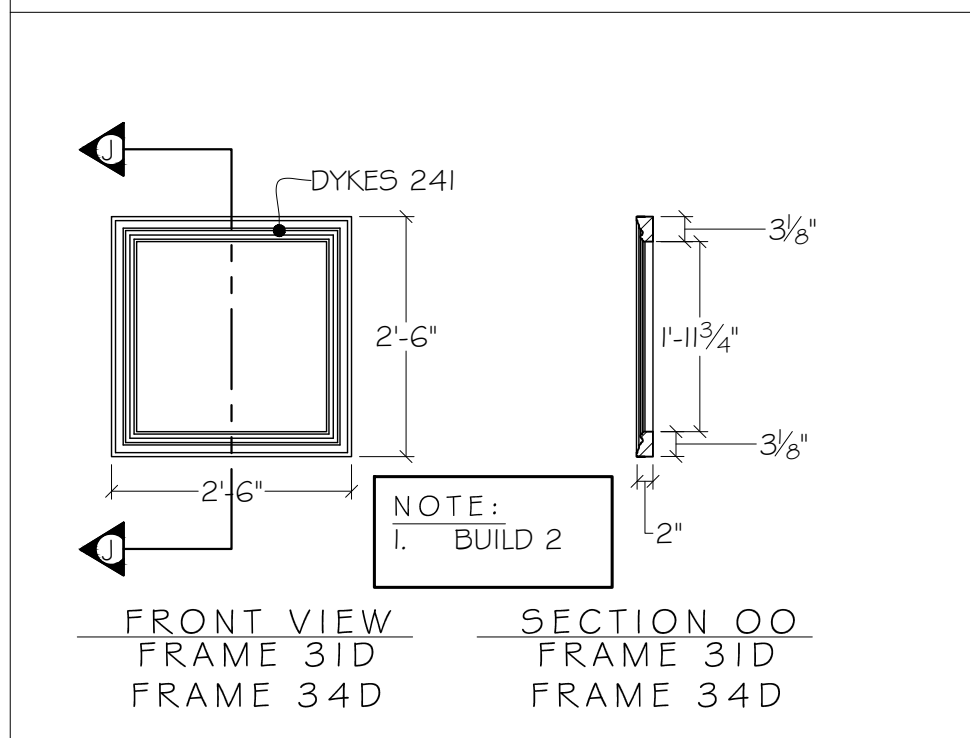
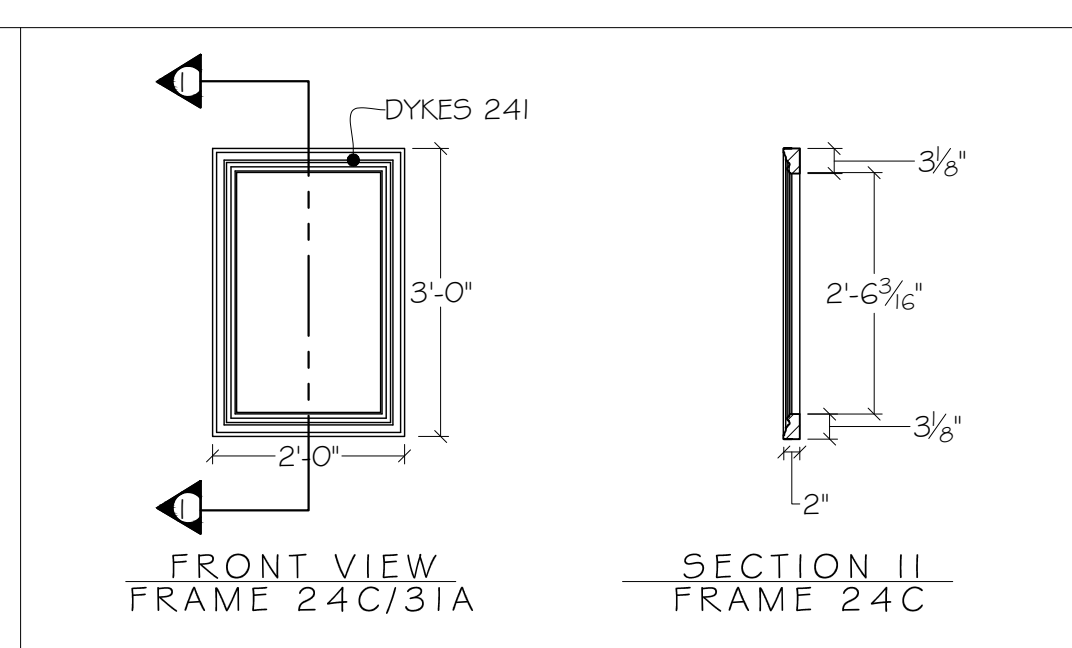
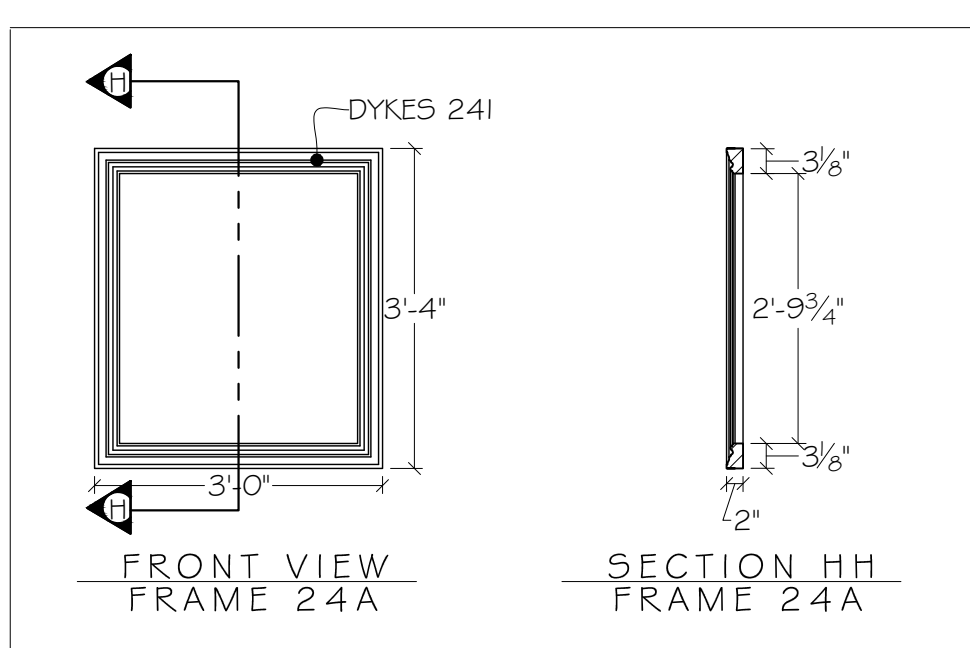
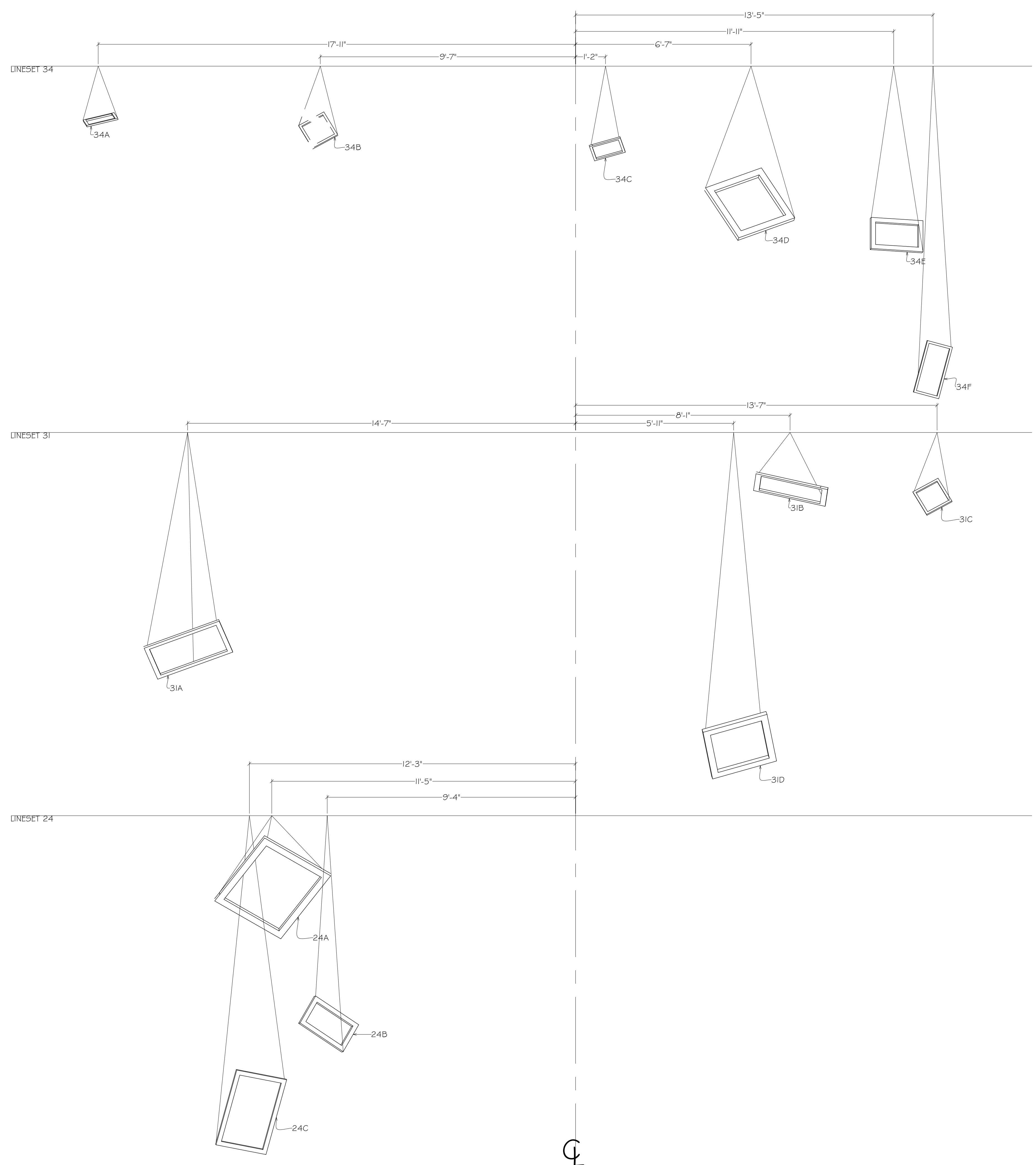

NOTE:
1. SIMILAR SIZED FRAMES CAN BE PURCHASED RATHER THAN BUILT IF NECESSARY

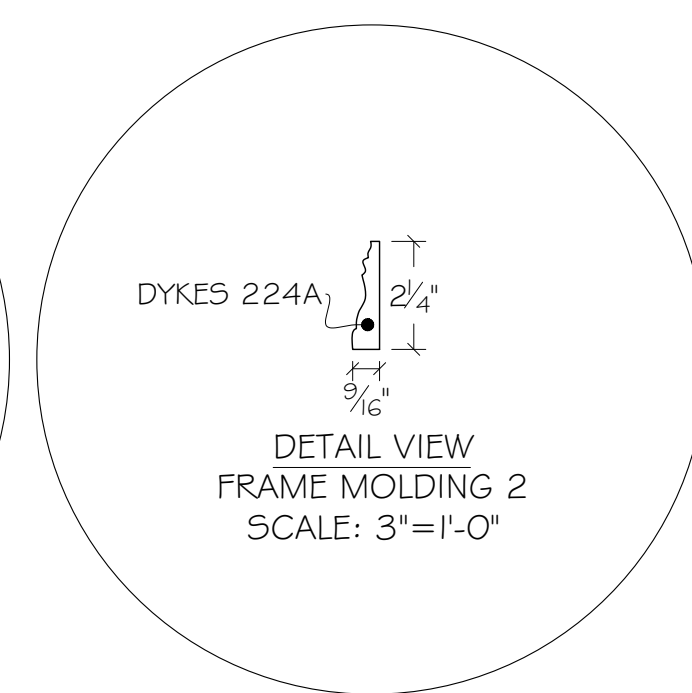
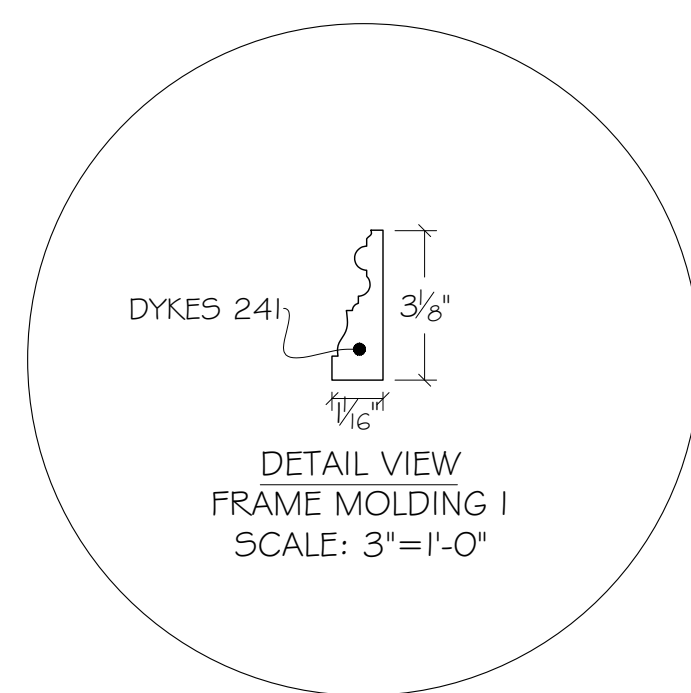
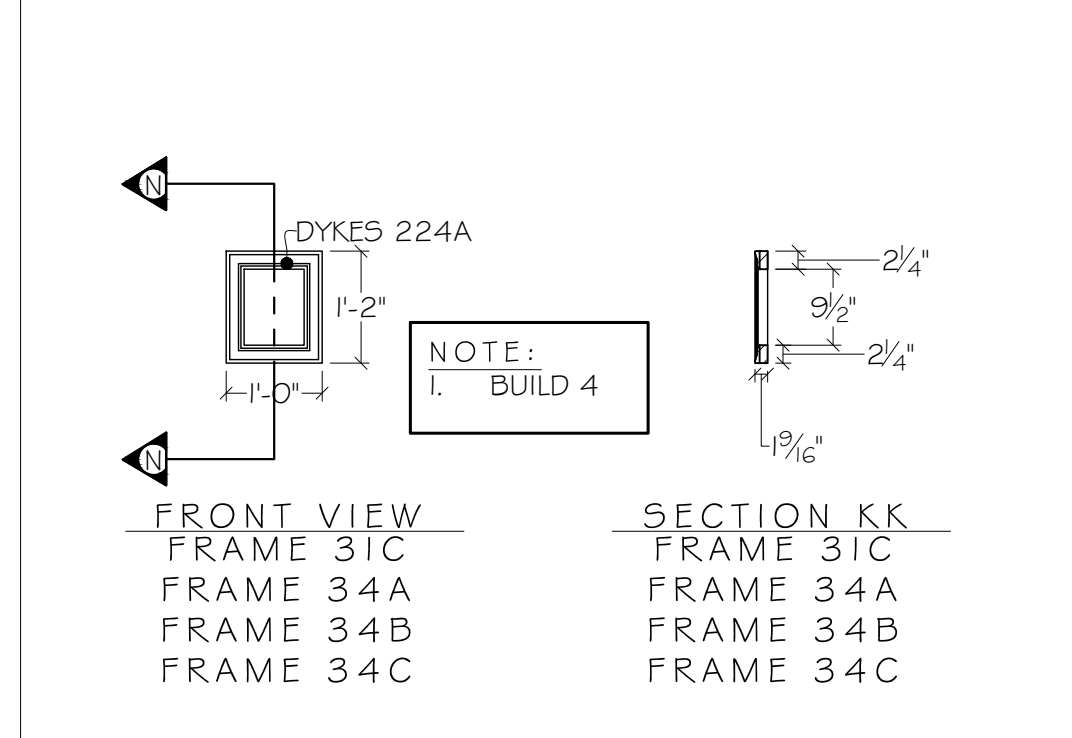
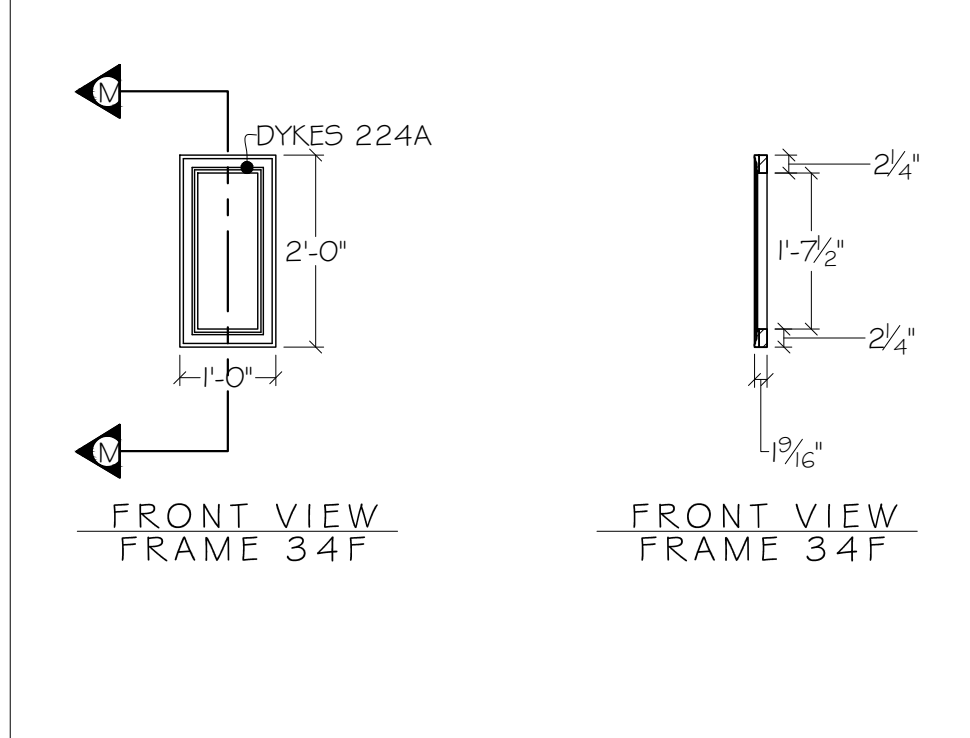
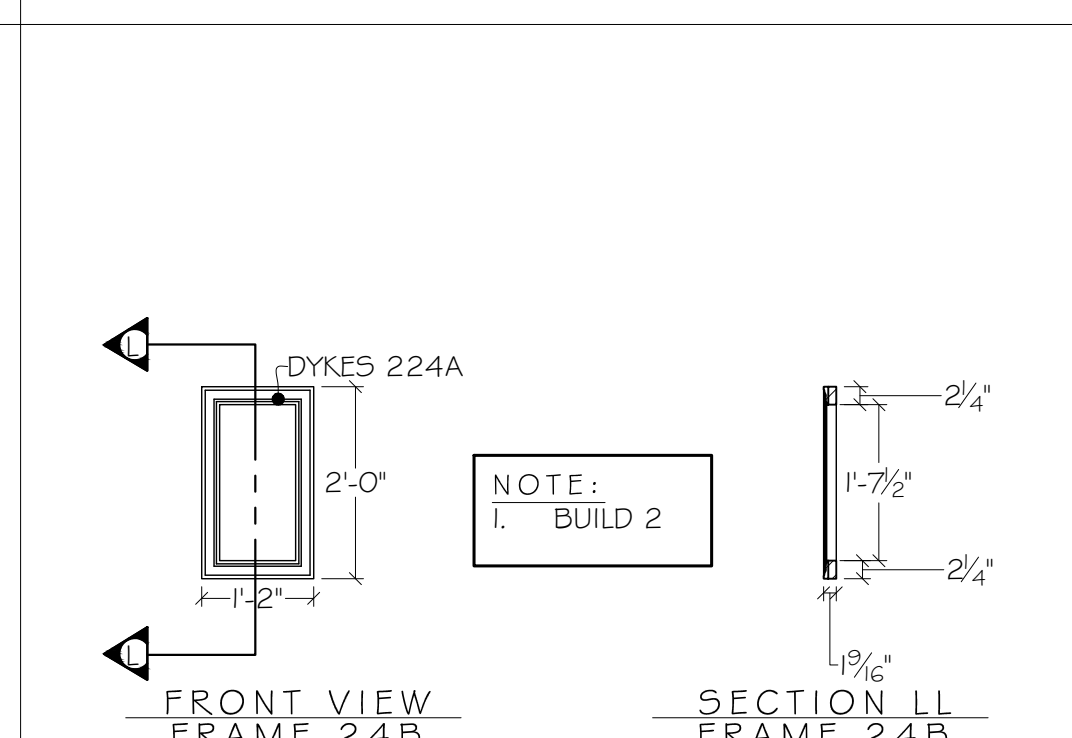
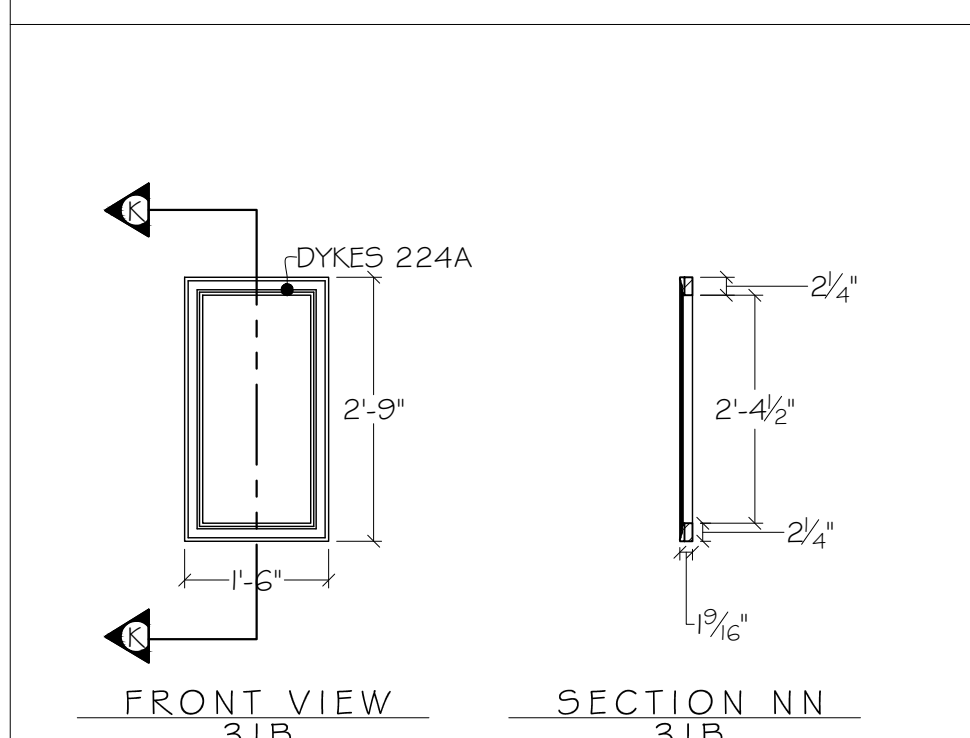

- NOTES:
- THERE ARE A TOTAL OF 13 FRAMES OF VARIOUS SIZES, HUNG ON VARYING ANGLES; ANGLES DO NOT NEED TO BE SPECIFIC, SO LONG AS THEY ARE NOT HOMOGENOUS
 - LIGHTING MAY SPECIFY CERTAIN ANGLES DURING FOCUS ON CERTAIN FRAMES, AS THEY PLAN TO LIGHT THROUGH THE FRAMES

ALL MATERIALS, CONSTRUCTION AND FINISHES MUST COMPLY WITH THE MOST STRINGENT APPLICABLE FEDERAL AND LOCAL SAFETY CODES.

THIS DRAWING AND ALL THE IDEAS, ARRANGEMENTS, DESIGNS AND PLANS CONTAINED HEREIN OR REPRESENTED THEREBY ARE OWNED AND REMAIN THE PROPERTY OF THE DESIGNER, AND HAVE BEEN CREATED AND DEVELOPED FOR USE ON, AND IN CONNECTION WITH, THE PROJECT SPECIFIED. NEITHER THIS DRAWING, NOR ANY OF SUCH IDEAS, ARRANGEMENTS, DESIGNS OR PLANS SHALL BE APPROPRIATED BY OR DISCLOSED TO ANY PERSON, FIRM OR CORPORATION FOR ANY USE WHATSOEVER, EXCEPT BY SPECIFIC AND WRITTEN PERMISSION OF THE DESIGNER.

WRITTEN DIMENSIONS ON DRAWINGS SHALL HAVE AUTHORITY OVER SCALED CONSTRUCTION AND MANUFACTURERS SHALL VERIFY AND BE RESPONSIBLE FOR ALL DIMENSIONS AND CONDITIONS ON THE JOB, AND SHALL INFORM THE DESIGNER OF ALL VARIATIONS FROM DRAWINGS PRIOR TO PERFORMING THE WORK. THE DESIGNER SHALL FIRST SEE AND APPROVE CONTRACTOR'S FULL-SIZE DETAILS BEFORE ANY FABRICATION IS BEGUN.

THESE DRAWINGS REPRESENT VISUAL CONCEPTS AND CONSTRUCTION SUGGESTIONS ONLY. THE DESIGNER AND HIS/HER EMPLOYEES AND ASSISTANTS ARE NOT QUALIFIED TO DETERMINE THE STRUCTURAL APPROPRIATENESS OF THESE SUGGESTIONS, AND WILL NOT ASSUME RESPONSIBILITY FOR IMPROPER ENGINEERING, CONSTRUCTION AND/OR HANDLING OF THE SCENERY REPRESENTED HEREIN.

SCALE: 1/2" = 1'-0" AS NOTED
 DRWG: RACHEL ROSE BURKE
 DATE: 03/05/2021
 REVISION(S):

DRAWING TITLE
HANGING PICTURE FRAMES

SHEET NO.

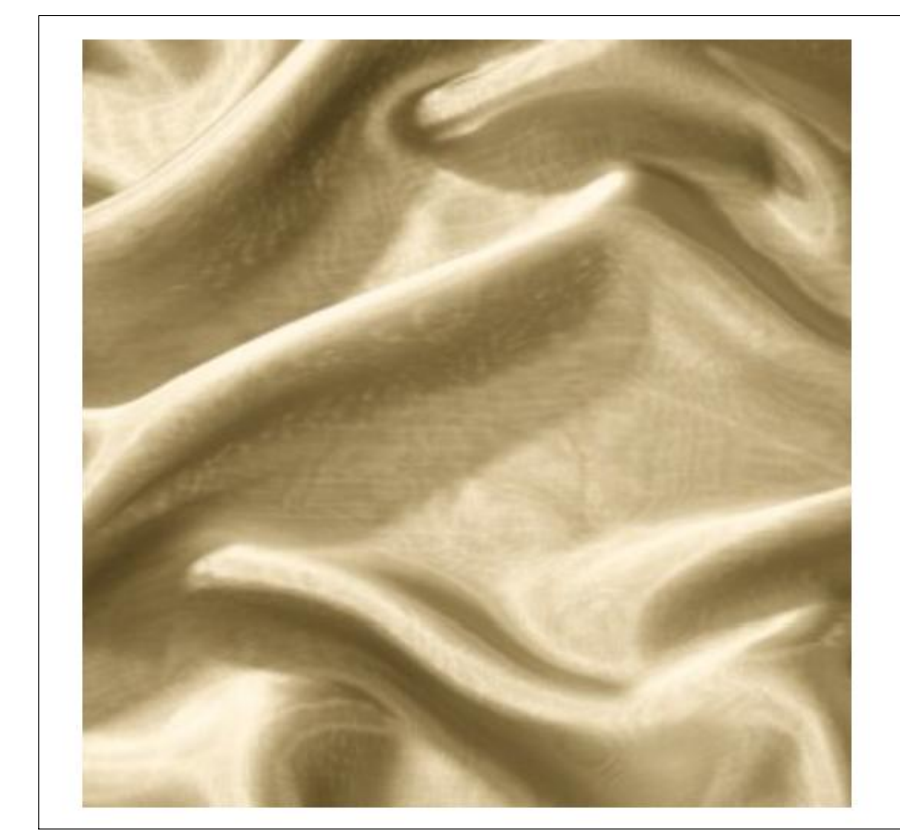
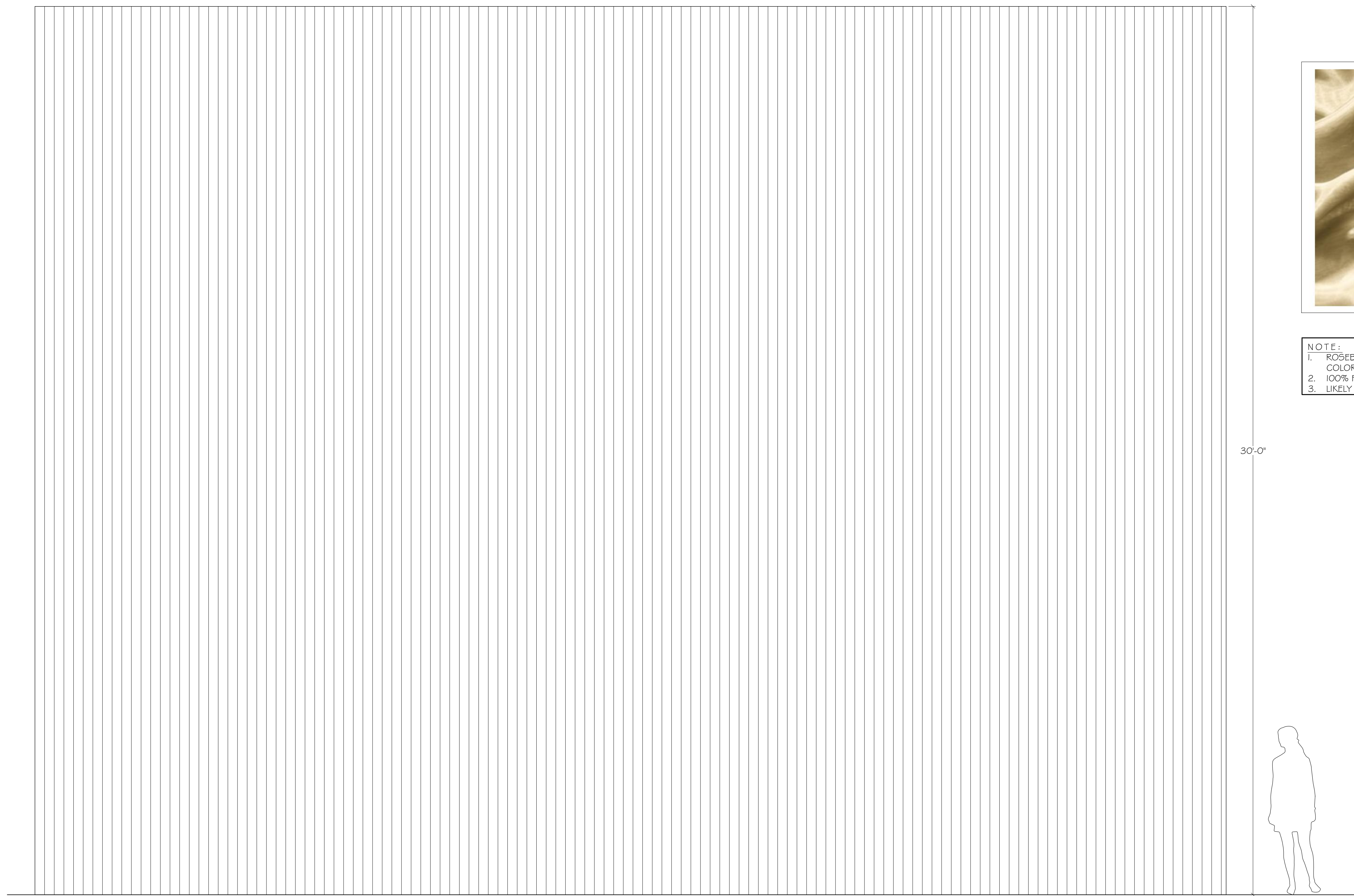

NOTE:
 1. ROSEBRAND, 58" ICICLE FR,
 COLOR: MIMOSA
 2. 100% FULLNESS
 3. LIKELY NEED APPROX. 160 YDS

30'-0"

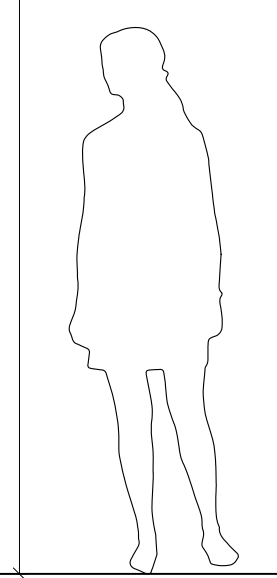

FRONT VIEW
SHEER CURTAIN

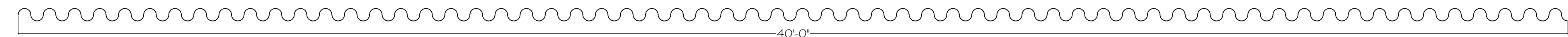

40'-0"

PLAN VIEW
SHEER CURTAIN

ALL MATERIALS, CONSTRUCTION AND FINISHES MUST COMPLY WITH THE MOST STRINGENT APPLICABLE FEDERAL AND LOCAL SAFETY CODES.
 THIS DRAWING AND ALL THE IDEAS, ARRANGEMENTS, DESIGNS AND PLANS CONTAINED HEREIN OR REPRESENTED THEREBY ARE OWNED AND REMAIN THE PROPERTY OF THE DESIGNER, AND HAVE BEEN CREATED AND DEVELOPED FOR USE ON, AND IN CONNECTION WITH, THE PROJECT SPECIFIED. NEITHER THIS DRAWING, NOR ANY OF SUCH IDEAS, ARRANGEMENTS, DESIGNS OR PLANS SHALL BE APPROPRIATED BY OR DISCLOSED TO ANY PERSON, FIRM OR CORPORATION FOR ANY USE WHATSOEVER, EXCEPT BY SPECIFIC AND WRITTEN PERMISSION OF THE DESIGNER.
 WRITTEN DIMENSIONS ON DRAWINGS SHALL HAVE AUTHORITY OVER SCALED DIMENSIONS. CONTRACTORS AND MANUFACTURERS SHALL VERIFY AND BE RESPONSIBLE FOR ALL DIMENSIONS AND CONDITIONS ON THE JOB, AND SHALL INFORM THE DESIGNER OF ALL VARIATIONS FROM DRAWINGS PRIOR TO PERFORMING THE WORK. THE DESIGNER SHALL FIRST SEE AND APPROVE CONTRACTOR'S FULL-SIZE DETAILS BEFORE ANY FABRICATION IS BEGUN.
 THESE DRAWINGS REPRESENT VISUAL CONCEPTS AND CONSTRUCTION SUGGESTIONS ONLY. THE DESIGNER AND HIS/HER EMPLOYEES AND ASSISTANTS ARE NOT QUALIFIED TO DETERMINE THE STRUCTURAL APPROPRIATENESS OF THESE SUGGESTIONS AND WILL NOT ASSUME RESPONSIBILITY FOR IMPROPER ENGINEERING, CONSTRUCTION AND/OR HANDLING OF THE SCENERY REPRESENTED HEREIN.

SCALE: 1/2" = 1'-0"
 DRWG: RACHEL ROSE BURKE
 DATE: 03/05/2021
 REVISION(S):

DRAWING TITLE
SHEER CURTAIN

SHEET NO.
9